

PART TWO

# History of Panel-Making Techniques

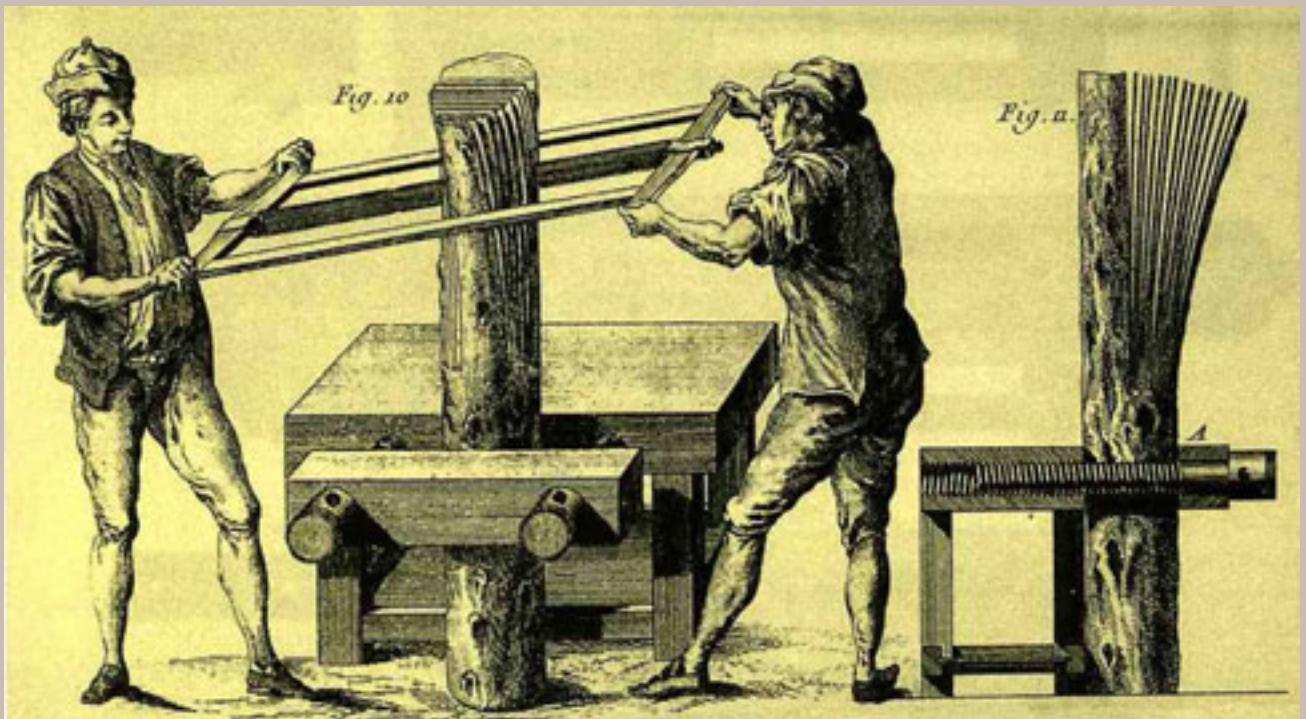

# Historical Overview of Panel-Making Techniques in Central Italy

Luca Uzielli

THE PRESENT STUDY surveys the techniques used in the making of the wooden supports of panel paintings in central Italy between the thirteenth and sixteenth centuries, a period during which panels played a particularly significant role in Italian painting.<sup>1</sup> An “evolution” in manufacturing techniques, however, does not imply that later panels were technologically more advanced than earlier ones. On the contrary, these changes may be regarded as an “involution,” which eventually led to an abandonment of wood in favor of canvas as a support material. During the historical period discussed in this article, supports for wooden panels were subjected to a wide range of influences: changing formal requirements of panel size and shape, including changes in artistic techniques and traditions, the challenges posed by economic constraints, and the need to develop woodworking techniques that would permit panels to respond to fluctuations in environmental conditions.

---

## Early References to Wooden Supports

Perhaps the first detailed information concerning early wooden supports in Italy can be found in *De Coloribus et Artibus Romanorum* by Eraclius (ca. tenth century C.E.). In the eleventh or twelfth century, Theophilus reported further information on the same subject in his *Diversarum Artium Schedula*, the most thorough medieval text dealing with the secrets and techniques of the fine arts. It describes how boards are glued together to form a whole panel for painting and how they may be coated with leather, to which the ground can be applied.

The richest and most detailed information about art techniques in the early literature, however, emerges from Tuscany in the early fifteenth century. While living in the town of Padua, Cennino d’Andrea Cennini, in his classic work *Libro dell’arte* (ca. 1437), described the techniques used in Florence (Cennini 1994). This text was “composed as for the use and good and profit of anyone who wants to enter the profession,” which was, he noted, “really a gentleman’s job” (Cennini 1994:chap. 145, p. 91).

Cennino’s recommendations about how an artist should be trained, what pupils should learn from masters, and how experience should flow through the *botteghe*, or workshops, provide an outline of typical techniques used at the time in preparing panel supports and reflect the highly serious attitude taken toward the craft:

Know that there ought not to be less time spent in learning than this: to begin as a shopboy studying for one year, to get practice in drawing on the little panel; next, to serve in a shop under some master to learn how to work at all the branches which pertain to our profession; and to stay and begin the working up of colors; and to learn to boil the sizes, and grind the gessoes; and to get experience in gessoing anconas, and modeling and scraping them; gilding and stamping; for the space of a good six years. Then to get experience in painting, embellishing with mordents, making cloths of gold, getting practice in working on the wall, for six more years; drawing all the time, never leaving off, either on holidays or on workdays. And in this way your talent, through much practice, will develop into real ability. (Cennini 1994:chap. 104, p. 64)

A thorough knowledge of various wood species and their properties and uses appears throughout Cennino's writing (see Table 1). That Cennino clearly takes information on wood species for granted suggests that it was common knowledge at this time. However, no mention is made of processing logs into boards, nor of selecting, edging, shaping, drying, or gluing of boards together to form the whole support. This absence may indicate that such expertise was not considered to belong to the artist's field, although the artist would often have specified the size, shape, and other features of the finished panel.

---

## Panel Construction Techniques

### Historical evolution of central Italian panel supports

The techniques used in the construction of central Italian wooden supports vary widely according to the period, region, type of artwork, and artist. It should be noted that the morphology and the structural complexity of a support are not directly related to the size of the painting nor to that of the individual boards but, rather, to the period to which it belongs. However, due to the nature of wood, which includes such properties as anisotropy and hygroscopicity, almost all supports shared some common features. The common sensibility that characterized the artisans of central Italy arose from an effort to provide simple solutions to the challenges posed by their craft.

The historical evolution of central Italian panel supports is interesting to follow. The supports of Tuscan paintings (*protopittura toscana*) that were produced until approximately 1250–80 possibly derive from Gothic retables and are made primarily of coniferous wood. During the late thirteenth, fourteenth, and early fifteenth centuries, poplar was the main species used. The complex nature of many paintings (e.g., altarpieces, crucifixes, polyptychs) often required that the support be a complex structure, an artwork in itself strengthened by ad hoc components, such as crossbeams, braces, and the framework on the reverse. Richly molded or carved engaged frames, predelle, cusps, and various ornaments constituted integral parts of the support. The conception of the supports, as well as the details of their manufacture, make clear the skills and knowledge of the artists and manufacturers with regard to the properties and behavior of wood. Even smaller paintings were often made on rather complex supports.

In the second half of the fifteenth century, works of art (including polyptychs and frescoes) made by fourteenth-century masters sometimes

*Table 1* Wood species mentioned by Cennino Cennini in the *Libro dell'arte*. Sources: English names (as translated by Thompson); page and chapter where the species is mentioned (Cennini 1994); Italian names in Cennini's original text; and the most likely scientific names (Giordano 1988; Schweingruber 1990), according to the judgment of the present author.

Thompson's translation	Page	Chapter	Italian name in Cennini's text	Latin name
Box	4	5	bosso	<i>Buxus sempervirens</i> L.
Broom <sup>a</sup>	87	142	scopa	<i>Erica scoparia</i> L.
Chestnut	41	64	castagno	<i>Castanea sativa</i> Mill.
Fig	4	6	figàro	<i>Ficus carica</i> L.
Linden	69	113	tiglio	<i>Tilia cordata</i> Mill.
id.	87	141	id.	id.
Male oak	118	174	rovere	<i>Quercus</i> sp.
Maple	41	64	àrgiere	<i>Acer pseudoplatanus</i> L.
Nut <sup>b</sup>	61	97	noce <sup>b</sup>	<i>Juglans regia</i> L.
id.	110	170	id.	id.
id.	116	173	id.	id.
Oak	118	174	quercia	<i>Quercus</i> sp.
Pear	61	97	pero	<i>Pyrus communis</i> L.
id.	116	173	id.	id.
Plum	61	97	susino	<i>Prunus domestica</i> L.
Poplar	69	113	arbero <sup>c</sup>	<i>Populus alba</i> L.
id.	87	141	albero <sup>c</sup>	id.
Whitewood	69	113	povolare <sup>c</sup>	id.
Willow	19	33	saligàro	<i>Salix</i> sp.
id.	69	113	id.	id.
id.	110	170	id.	id.

<sup>a</sup>"Broom," rather than "birch," is most likely the correct English translation for the species cited by Cennino.

<sup>b</sup>The correct English name for *noce* is walnut.

<sup>c</sup>Both *albero* (or *arbero*) and *povolare* meant poplar; the current Italian common name for *Populus alba* is *gattice*.

underwent a modernization. This was undertaken not only to repair damages but in many cases to adapt the works to the requirements of new locations or new aesthetic criteria and rules (Filippini 1992; Gardner von Teuffel 1983). In such cases, significant structural modifications occurred to the wooden supports and to the frames.

In the fifteenth and sixteenth centuries, the supports became more sober in design, evolving toward a simple panel composed of various boards inserted in a separate frame. The ground layer also became simpler (see following section).

Usually, the construction of the wooden support was the responsibility of a specialized artisan (the *legnaiolo*), who could work independently of the artist and could even prepare a support according to a client's specifications before the artist was chosen (Bernacchioni 1992). However, especially in the case of the earlier, more complex panel paintings, close cooperation must have existed with the artist, who probably gave the car-

painter specific directions, even on subjects relating to the manufacture of the support. In Duccio's *Maestà*, for example, the aesthetic interaction between painting and front frame suggests an intervention by both artist and carpenter, even if such was not provided for by the contract.

In some cases, a specific artist would have had his own carpenter or would have consistently used the services of the same bottega. For example, the same hand may be recognized in several supports of Giotto's paintings, including the *Maestà di Ognissanti* and the *Crocifisso di Santa Maria Novella*. Filippo Lippi and Sandro Botticelli also had exceptional carpenters.

## Ground layers

Up to the fourteenth century, great care was used in preparing the ground layer, which, as described by Cennino, was basically made of glue, cloth, *gesso grosso*, and *gesso sottile*. The cloth, generally made of large, overlapping pieces, was often applied not only over the whole panel but over the engaged frame as well (see Fig. 1).<sup>2</sup>

In the fifteenth century, cloth strips were often applied only on the most sensitive areas (such as joints between boards, or knots and other defects in the wood), whereas in later years parchment or vegetable fibers mixed with glue were used. Increasingly, less care was devoted to gessoing.

Correctly chosen and applied cloth created the best results; even in cases where wood movement caused the whole complex of cloth together with the ground layer to separate from the wood, the painting often remained well preserved. In contrast, parchment tended to detach extensively and lift at the edges. Likewise, vegetable fibers did not perform as strongly and efficiently as does the woven structure of cloth. The absence of cloth and the limited care applied to the ground layer resulted in a greater likelihood that wood movement would affect the paint layer, which then suffered from characteristic damage, such as lifting and corrugation into numerous small crests.

## The selection of wood species for panels

Although it is customary to think of "supports made of wood," it would be more precise to refer to "supports made from one or more wood

*Figure 1*  
Giotto, *Crocifisso di Santa Maria Novella*.  
Church of Santa Maria Novella, Florence.  
Coarse and thin cloth glued on planking and  
on frame moldings.

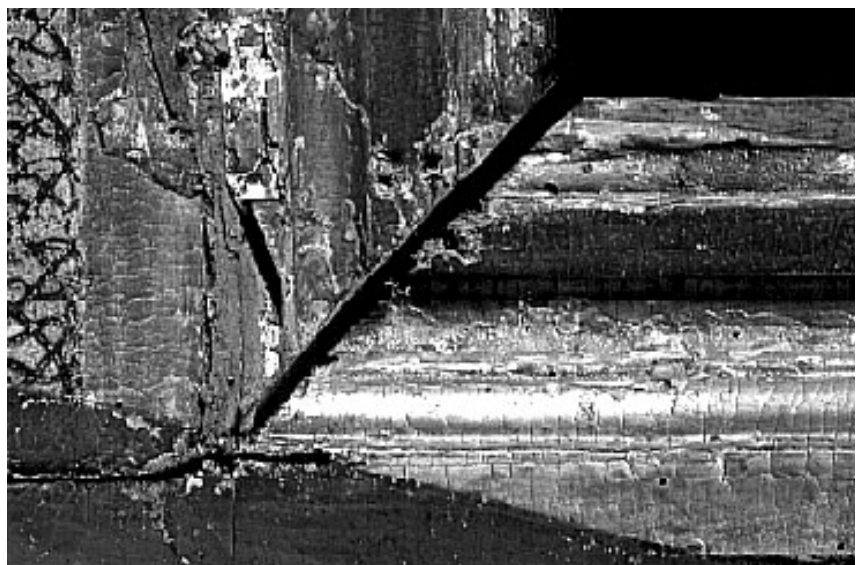

species, each having its own individual technological properties.” The conservation and behavior of a wooden support during its lifetime are significantly influenced by the wood species used. The selection of a wood species for a panel depended on technical, economic, and practical factors. It was also influenced by the particulars of the artisan traditions.

As already mentioned, earlier supports were made mostly of coniferous wood, especially fir (*Abies alba* Mill.). Later, beginning in the second half of the thirteenth century, poplar (*Populus alba* L. and other *Populus* spp.) started to be used on most panels throughout central Italy.<sup>3</sup> Other wood species have also been used occasionally through the centuries, including walnut (*Juglans regia* L.), linden (*Tilia cordata* Mill.), oak (*Quercus* spp.), chestnut (*Castanea sativa* L.), and others.<sup>4</sup> Engaged frames were mostly made of poplar (especially the earlier examples, which were manufactured integrally with the panel), since the same wood properties were required for the engaged frames as for the panel. The framework on the back (including the crossbeams) was usually made of wood species selected for their strength and rigidity.

The choice of wood by local artisans was strongly influenced by questions of availability and cost. Marette shows that wood species for supports were typically chosen among those growing in the region (Marette 1962).

This and a number of other reasons help explain why poplar was the species most frequently used for panels. Poplar is technically suitable for the manufacture of supports. Poplar’s heartwood is undifferentiated, and the absence of extractives such as tannins makes adhesion of glues and ground layers easier and more secure and prevents leaching and staining in the event of high moisture. It is homogeneous, being fine textured, with not much difference between earlywood and latewood, or between normal wood and knots. Poplar also exhibits good dimensional stability in the presence of humidity variations, due to its small shrinkage and distortion coefficients. Moreover, it is strong, light, and easy to dry and process. It offers a plentiful source of large, regular, straight-grained, and relatively defect-free boards. As for its availability, poplar’s natural growing area covers practically all of Italy.

The major drawbacks of poplar are its low natural durability against fungi and its nonresistance to wood-boring insects, both a consequence of the absence of extractives.

There is little doubt that poplar (and other similar but less used species, such as linden and willow) was technically a better choice for panels than was fir, the species that had been most widely used previously. Fir is as fine textured and easily processed as poplar, but it is not as homogeneous. With fir, alternating earlywood and latewood tend to show up through the thinner ground layers, and knots are more frequent and prominent. In addition, fir has less dimensional stability than poplar, and it reacts more quickly to changes in environmental humidity.

Until the middle of the thirteenth century, techniques used in northern Europe, including the use of fir, influenced those in central Italy. At some point, however, the idea may have emerged that poplar would fare better in the highly variable Tuscan climate, which subjects panel paintings to great mechanical stresses. This idea may have been a consequence of the greater autonomy in social, political, economic, and artistic spheres in Florence beginning in the thirteenth century. This



Figure 2  
Guglielmo, *Croce dipinta*, 1138. Cathedral of Sarzana. The support of this very old cross is made of chestnut.

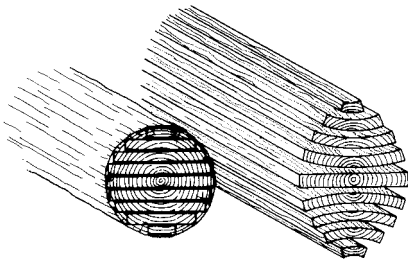

Figure 3  
Drawing depicting the sawing of a log and typical deformations of boards after seasoning. Only radial boards remain flat after moisture variations.

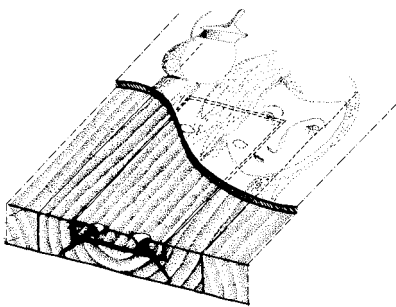

Figure 4  
Diagram showing a diametrically cut board made weak by the presence of the pith, which had been removed and replaced by an inset before the ground and the paint layer were applied. Giotto, *Maestà*. Uffizi Gallery, Florence.

autonomy led artists and artisans involved in panel painting to adopt techniques better fitted to local conditions, creating a change of attitude among artists that accompanied the moral and cultural shift that is made clear in Cennino's *Libro dell'arte*. This movement also indicated another shift: the basis for pride in the artwork itself was no longer limited to the achievement of creating a panel that would serve solely as a devotional instrument in the present and near future; pride was also based on the creation of an enduring work of art that would last for posterity.

Economic or time constraints might have encouraged the occasional use of cheaper or more immediately available wood, although at times locally available, well-known woods may have been preferred and deliberately chosen (e.g., chestnut for the support of Guglielmo's painted *Croce* from the Sarzana Cathedral) (Fig. 2). In some cases, artisans may not even have considered the implications of using different species. In reporting on microscopical identification of recently exhibited paintings by Raphael, for example, Fioravanti (1994) concluded that poplar and linden were used interchangeably by the artist.<sup>5</sup> It is also possible that different woods may have been used deliberately for the sake of amusement or experimentation; however, in the cases of complex supports or later interventions, it is likely that an artisan would simply have used any piece of wood available in the workshop.

### Wood quality

There is little doubt that no matter how appropriate a wood species seems, boards that are badly manufactured, selected, or seasoned result in undesirable behavior. There is also no doubt that wood properties and behavior were well known by the artisans who made the supports.

### Sawing patterns and arrangement of growth rings

Since it is well known that after seasoning, radial boards distort (cup) much less than tangential boards (Fig. 3),<sup>6</sup> it has often been thought and taught that good workmanship requires that only radial boards be used for panel paintings. Although this is true in some cases (e.g., for oak supports used in central and northern Europe), it does not always apply to poplar supports in central Italy for a number of reasons.<sup>7</sup> Although diametrically cut boards can be considered the optimum choice for poplar panels, they were not absolutely required. On the one hand, a diametric board offers two advantages: first, it is the widest board that can be obtained from a given log, and second, it is less prone to cupping than any other board, due to its radial cut. On the other hand, a diametric board has the disadvantage of containing the log's pith, which constitutes a zone of discontinuity and low strength that is prone to longitudinal cracks (Fig. 4).<sup>8</sup> From an economic standpoint, since most logs were likely sawn according to a parallel pattern, a technique that produces a high proportion of tangential and subtangential boards, selecting only the diametric board from each log would result in an unjustified waste of good and expensive wood material. Another economic consideration is that a greater number of tangential and subtangential boards result from a log that is parallel sawn.

As for the arrangement of boards according to their growth-ring orientation, it appears that no general rule may be determined. Boards were often arranged with the "inner" face toward the side to be painted.<sup>9</sup>

However, in many cases no specific arrangement according to growth rings can be observed. Boards with “inner” faces oriented one against the other (one toward the front and one toward the back of the panel) have also been noted (Fig. 5).

This question of board arrangement may be less critical than it appears at first, since the effects of other distortion factors (i.e., the temporary cupping caused by mechanical or hygroscopic asymmetry and the permanent cupping caused by what Buck has termed “compression set”) are superimposed and may even prevail over the cupping caused by the wood’s transverse anisotropy (Thomson 1994; Uzielli 1994).

### Avoiding and repairing wood or board defects

Even the most carefully built fourteenth-century panels, which are characterized by the great care that was taken in wood selection, contain some defects, suggesting that the use of some boards with defects was considered acceptable.<sup>10</sup> The most frequent wood defects found in panels are pith, knots, and grain deviations, whereas board defects relate mostly to wane appearing on the back face.<sup>11</sup> The presence of wane shows that boards have been used at the maximum of their available width and that sapwood is present.<sup>12</sup>

In addition to the gluing of cloth over the defective area before the ground layer was applied, a number of other measures were often taken to prevent or, at least, to reduce the negative consequences of defects in selected boards. Knotholes and similar cavities were plugged with a paste made of glue and sawdust (as Cennino recommends) or with tightly embedded wooden plugs placed with their grain parallel to that of the board (Fig. 6). If wane or a relatively large decayed or defective area were present on the front of the panel, a flat surface was sometimes reconstructed before the application of the ground layer. In the thirteenth and fourteenth centuries, such reconstruction was usually accomplished by the precise embedding of small boards (Fig. 7). Later, various materials were used to plug the voids, including glue paste with sawdust or vegetable fibers (Del Serra 1994).

With respect to widespread incipient decay in boards selected for panel making (the decay of wood in the panel after painting is not discussed here), there is a possibility, which has not been unequivocally confirmed, that boards affected by some early stage of fungal decay (e.g., boards recovered from other uses or boards left exposed to weather) may have been purposely used for panel construction to take advantage of their reduced shrinkage and swelling.<sup>13</sup>

Figure 5

Cross section, obtained by computer tomography, of a panel painting made from two fir (*Abies alba* Mill.) boards, probably cut from the same log, with “inner” faces oriented one against the other (one is placed toward the front and one toward the back of the panel). *Madonna con Bambino*, twelfth or thirteenth century. 127 × 65 cm. Convento Suore Agostiniane della Croce, Figline Valdarno.

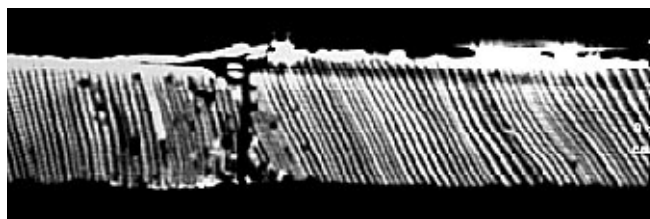
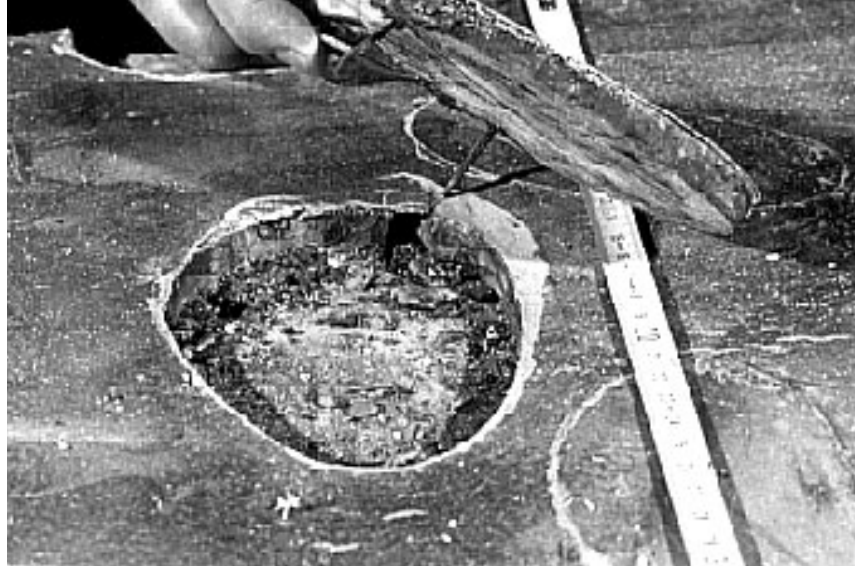



Figure 6

Francesco Salviati, *The Deposition from the Cross*, 1547–48. Oil on panel, 495 × 285 cm. Museo dell’Opera di Santa Croce, Florence. Wooden plug originally embedded in the panel face before painting.



### Seasoning

Anybody knowledgeable on the subject (see, for example, Cennini 1994:chap. 108) appreciates that for optimum results, timber should be perfectly seasoned. However, it is well known to artisans today—as it must have been to those of the Renaissance—that in practical terms, the designation “perfect” seasoning does not refer to a static situation or a fixed moisture content. The golden rule of the craft states that the equilibrium moisture content (EMC) of the wooden support at the time of manufacturing or painting should be as close as possible to the average EMC predicted in its subsequent environment.<sup>14</sup>

It may be impossible today to determine the exact values of the moisture content (MC) of supports at the time of their manufacture. One assumption, however, is that the average EMC of panel paintings located in churches, public buildings, or noble houses (most of them usually

Figure 7

Cimabue, *Maestà*. Uffizi Gallery, Florence. X radiograph of a small insert originally embedded in the face of a diametrical board possibly damaged near the pith, to restore flatness and continuity of the panel surface.



unheated) in central Italy might have been 12–16% (corresponding to typical air temperatures of 0–30 °C and relative humidities of 60–80%).<sup>15</sup>

In exceptional cases, insufficiently seasoned wood was used, as exemplified in the otherwise unexplainable width of gaps (a total of 4 cm over the panel's width of 293 cm) between the boards of Duccio's *Maestà* (Fig. 8) (Del Serra 1990).

### Size of boards

Most of the supports were made of two or more boards, depending on their size and shape. Only smaller supports were made of a single board. No general rules may be given on this subject since there is obviously great variability. Boards as wide as 60–70 cm or wider have been occasionally used, although 20–40 cm is the more common range of width.

Using wider boards would certainly have reduced the number of joins required for a panel and the consequent risk of separation along the glued joints. Thicker boards confer greater strength and rigidity, as well as greater dimensional stability under rapid environmental fluctuations.<sup>16</sup> However, disadvantages arise from their greater weight, greater manufacturing difficulties, and often unrestrainable forces that develop following environmental changes, possibly leading to severe distortions or damages (Uzielli 1994).

Typically, the original thickness of boards ranged between 30 mm and 45 mm, the thickness of large supports in particular being kept to a minimum to reduce total weight.<sup>17</sup> Larger boards usually required a greater thickness because of manufacturing techniques and the need to conserve planarity.

Strength and planarity of earlier and more complex panels were usually entrusted to the supporting system (frame, crossbeams, slats, braces, etc.), thereby reducing the need for proportionally thick boards in large paintings; in fact, 30 mm thick boards were often used. However, the boards of some larger supports from the fifteenth century feature greater

*Figure 8*  
Duccio, *Maestà*. Uffizi Gallery, Florence. Gaps between the boards caused by seasoning of wood after the panel was manufactured and painted.

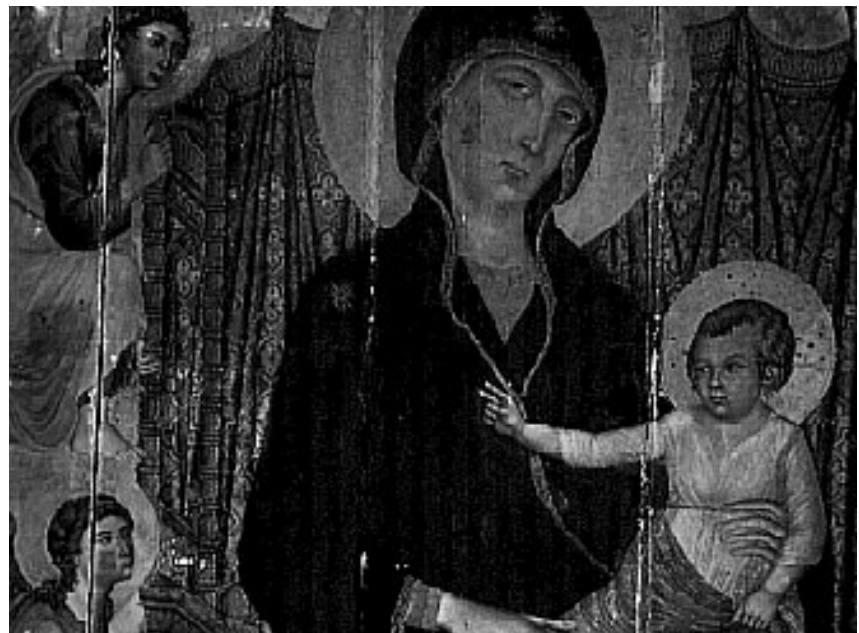

thickness (35–40 mm), possibly required by their size and their simpler structure, which entrusts the panel's strength and stability to the board's rigidity. The boards of later paintings from the sixteenth and seventeenth centuries are even thicker (40–45 mm) and are practically self-supporting—with crossbeams and slats that are usually intended to guarantee the continuity of the panel rather than its overall strength or shape.

In most cases thickness is constant throughout the whole panel; however, some panels were intentionally manufactured with varying thicknesses.<sup>18</sup> No satisfactory technical explanation has yet been given for this feature, which has been seldom reported in panels from central Italy.<sup>19</sup>

### Connections between boards

Boards were usually glued along their edges with “cheese glue” (casein) or hot-melt animal glue (made of clippings), both described by Cennino (Cennini 1994:chap. 108). Typically, boards were accurately square-edged before gluing, and occasionally several incisions were made on the edges, possibly to improve glue adhesion (Fig. 9).<sup>20</sup>

Casein glue, one of the strongest glues known, has been used by woodworkers since ancient times; it does not have tack,<sup>21</sup> and its pot life is relatively short. Hot-melt animal glue features an even shorter preassembly time, since it must be hot while pieces to be joined are pressed together. For both glues, therefore, the assembly of boards had to be performed in a relatively short time, and the process required accurate and definitive positioning before pressure was applied. To satisfy such requirements (which must have been demanding, especially for large supports), wood splines, or dowels, made of hardwood (such as oak or elm) were used (Fig. 10). The splines were circular (*cavicchi*) or rectangular (*ranghette*) in cross section. They fit into mortises bored in the board's thickness and were placed at appropriate distances along the edges in order to maintain the board position until the glue applied on the edges had set.<sup>22</sup>

Other methods for connecting boards, such as groove-and-tongue joints, were possibly also used in earlier times. However, such methods seem to make gluing more difficult, because the internal surfaces were hard to reach and to control. Half-lap joints were used only in special cases.

Although double-dovetailed (i.e., X-shaped) wooden cleats mortised in the boards (Fig. 11) are infrequently found in the original manufacture of central Italian supports, their use has been popular in later restorations, albeit with unsatisfactory results.<sup>23</sup>

As an interesting example, the three higher corners of the cuspidate front frame of the *Maestà* by Duccio featured X-shaped cleats mortised into the boards and then painted by the artist. The subsequent wood

Figure 9

Incisions on the edges of the board to improve gluing, and spline used for the alignment of boards during the setting of the glue. Francesco Salviati, *The Deposition from the Cross*.



Figure 10

Drawing of wooden splines used for positioning boards during the setting of the glue.

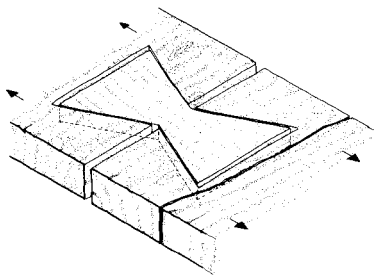
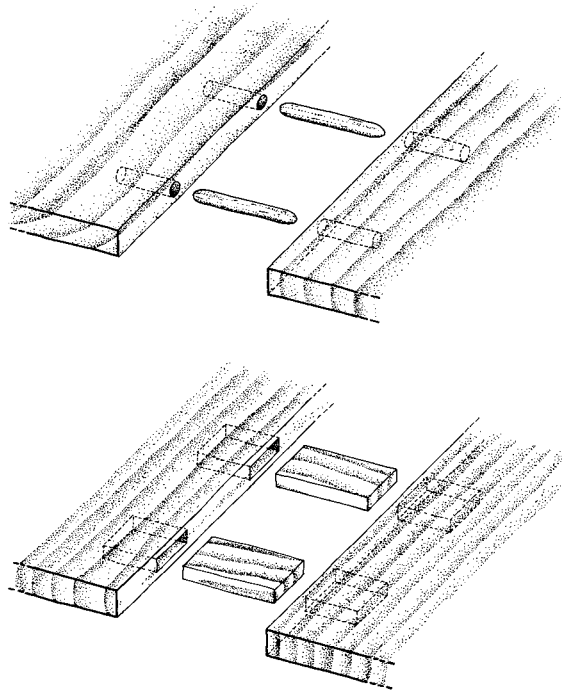

Figure 11

Drawing of X-shaped wooden cleat used to connect adjacent boards, mainly in later restoration works.



Figure 12

X-shaped wooden cleat used to connect two boards of the engaged frame after manufacture of the panel. Duccio, *Maestà*.

movements, in spite of the cleats, severely damaged the ground and paint layer in areas that correspond to the connections, whereas paint is fairly well preserved in other areas of the same front frame (Fig. 12) (Del Serra 1990).

There were several other types of connections—usually done with nails—between the various parts of wood supports. Examples can be seen in the added parts or lateral sealing of boards in thirteenth- or fourteenth-century crucifixes or altarpieces (Fig. 13) (Bracco, Ciappi, and Ramat 1992).

### Arrangement of boards

Usually a panel was made of boards placed parallel to one another.<sup>24</sup> The longitudinal axis of the boards coincided with grain direction and was oriented along the greater dimension of the painting. Less frequently, panels were formed by boards connected with their grain direction perpendicular to each other, end joined, or irregularly placed. There were various cases and reasons for this configuration. In painted crosses, the transverse arm was typically made of horizontal boards.<sup>25</sup> A half-lap joint (*incastro a mezzo legno*) was then made, and the two adjacent faces were glued together with the grains positioned at right angles. Dovetail joints and other joining methods were also used (Bracco, Ciappi, and Ramat 1992).

Evidence shows that in some cases modifications or additions of boards (including perpendicular additions) to the wooden support were made before the ground layer was applied, possibly to satisfy the requirements of the artist, who might have changed his mind or have been required to paint on a support that had already been prepared independently from personal specifications (for example, see Giotto's *Crocifisso di Santa Maria Novella*, Florence [Bracco, Ciappi, and Ramat 1992]).

Modifications also occurred as a consequence of later interventions on paintings, as a result of the need to replace deteriorated parts or to modify the shape, size, or proportions of a panel, as with Raphael's

Figure 13

X radiograph of the nailed lateral sealing boards in a crucifix. Giotto, *Crocifisso di Santa Maria Novella*.

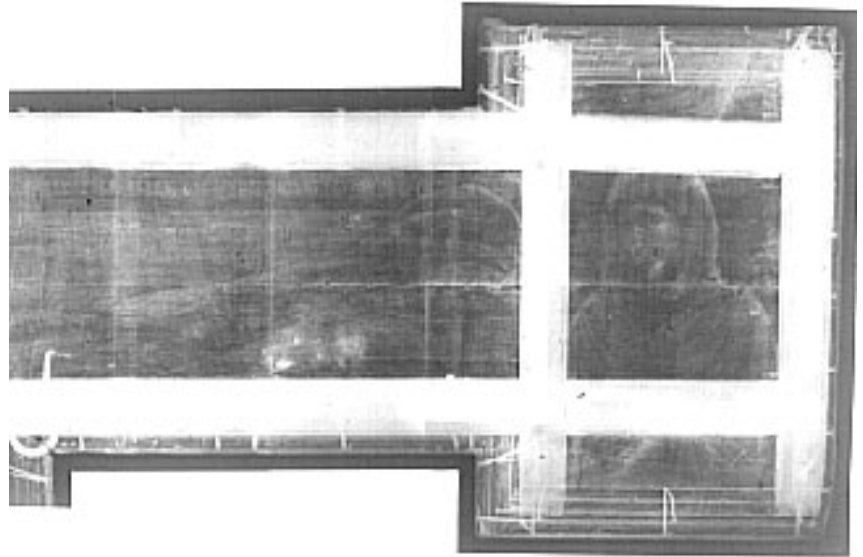

*Madonna del Baldacchino* (Fig. 14); for the purpose of fitting it in a different location; or to satisfy different aesthetic canons (Castelli, Parri, and Santacesaria 1992; Filippini 1992). Also included within this group are the countless paintings that have been dismembered, sawn, modified, or transformed for commercial reasons over the centuries.

### Crossbeams and “backframes”

Crossbeams or “backframes” (the latter, in Italian, *telai*, being basically combinations of crossbeams and longitudinal or oblique struts, or *nottole*) are present on most panel supports. Their main functions were to hold the panel together and maintain its general planarity, especially for large or

Figure 14

Raffaello Sanzio, *Madonna del Baldacchino*. Galleria Palatina, Florence. Drawing showing the structure of a panel originally formed by six vertical boards. In 1697 a horizontal board was added, connected by a half-lap glued joint and three smaller vertical nailed boards. Later the panel was cradled.

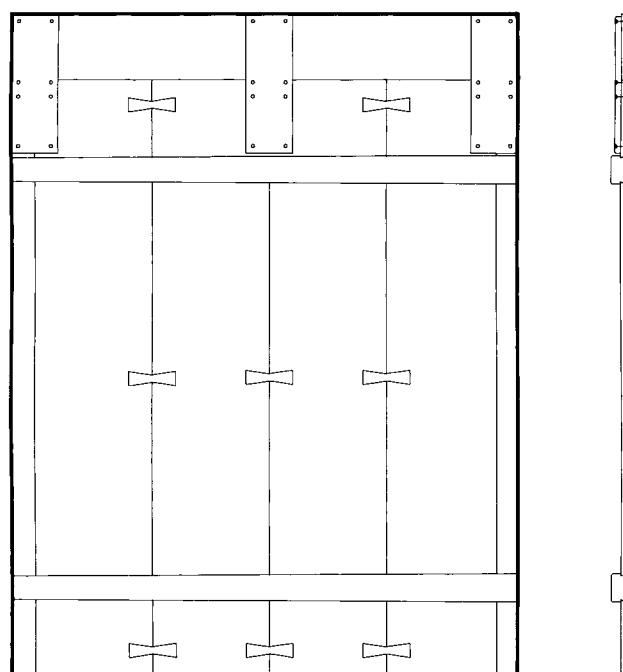

0.5 m

complex paintings,<sup>26</sup> even if separations at glue lines or fissures interrupted the structural continuity of the panel. They also distributed throughout the whole panel the forces originating at supports, hanging points, connections, and so on, and helped to conserve the painting by reducing the negative effects of swelling and shrinkage caused by unavoidable moisture changes (Uzielli 1994).

On all but the last point, there is general consensus. However, the question of whether crossbeams and backframes help conserve a painting is still quite controversial today, both in its theoretical and practical aspects. In fact, the real problem lies not in the lesser or greater complexity of the backframe but, rather, with the type and stiffness of the connections between the panel and crossbeams, as well as the stiffness of the crossbeams themselves.

Until the early fifteenth century, connections between panels and frames (including crossbeams and engaged frames, where appropriate) were made mostly with nails. Later, various types of sliding crossbeams, resting on the back face of the panel, were devised. In the late fifteenth and early sixteenth centuries, dovetailed crossbeams (trapezoidal in cross section), inserted in tapered or (rarely) parallel grooves mortised into the thickness of the panel, were often used. On a few occasions, crossbeams were glued.

The two criteria taken into consideration by artisans, along with their individual views and experience, in order to obtain the “controlled mobility” required from the crossbeams were, first, the distance between the crossbeams—defining the size of the transversal strip of panel that was “entrusted” to a crossbeam (which in fact was highly variable), and second, the thickness ratio (i.e., ratio of the thickness of the panel to thickness of the crossbeam), with an approximate range of 1:2–1:3.

It should be noted, however, that any general statement regarding the design of the backframe may do a disservice to the creativity and ability of the artisans. The few images given here serve only as examples (Figs. 15–17).

### Nailed crossbeams

Nailing is one of the oldest and most frequently used means of connecting pieces of wood. At least with regard to thirteenth- and fourteenth-century panels, nailing should not be considered primitive, rough, or technologically inadequate. On the contrary, a careful analysis shows just how wise and skillful the artisans were who conceived the structures and nailed them together.<sup>27</sup>

Nails were made of soft, wrought iron. The shanks were square or rectangular in cross section, tapered from their large, thin, round heads to their acuminate points (Fig. 18). They were driven by hammer into partially prebored holes and were clinched back into the wood in a U shape to ensure optimum resistance against pullout.<sup>28</sup>

The spacing of nails was regular and obviously well thought out. No strict spacing rules applied; the artisan’s wisdom defined the direction in which the nails were inserted (from the front toward the back or vice versa, or in both directions) (Fig. 19).<sup>29</sup>

Great care was usually taken in separating the nail’s end (head or clinched point) from the ground layer (Fig. 20) to prevent repercussions on the paint layers, such as surface irregularities or possible future emergence

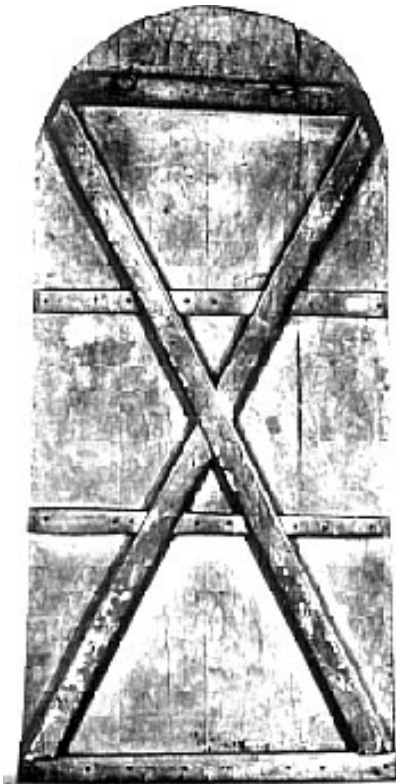

Figure 15  
Coppo di Marcovaldo, *Madonna in trono col Bambino*, reverse. Church of Carmine, Florence.

Figure 16

Giotto, *Maestà*, reverse, before the 1991 restoration.



Figure 17, below

Giotto, *Crocifisso di Santa Maria Novella*, reverse.

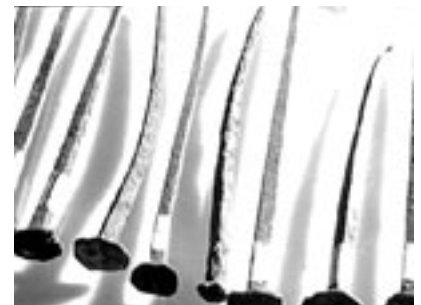
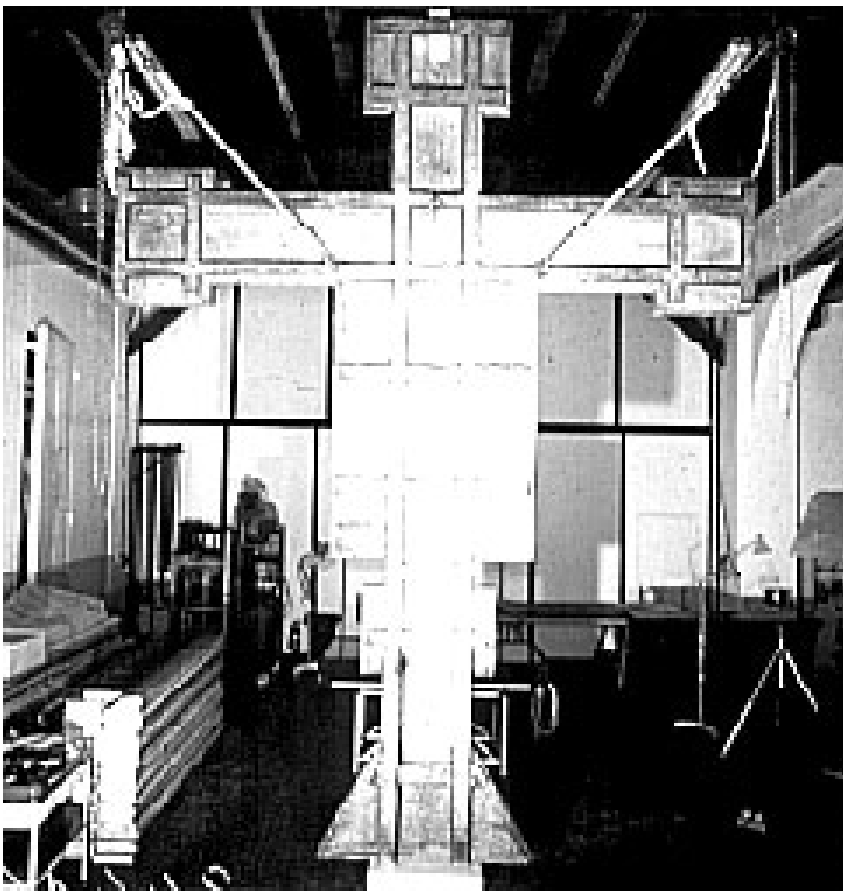
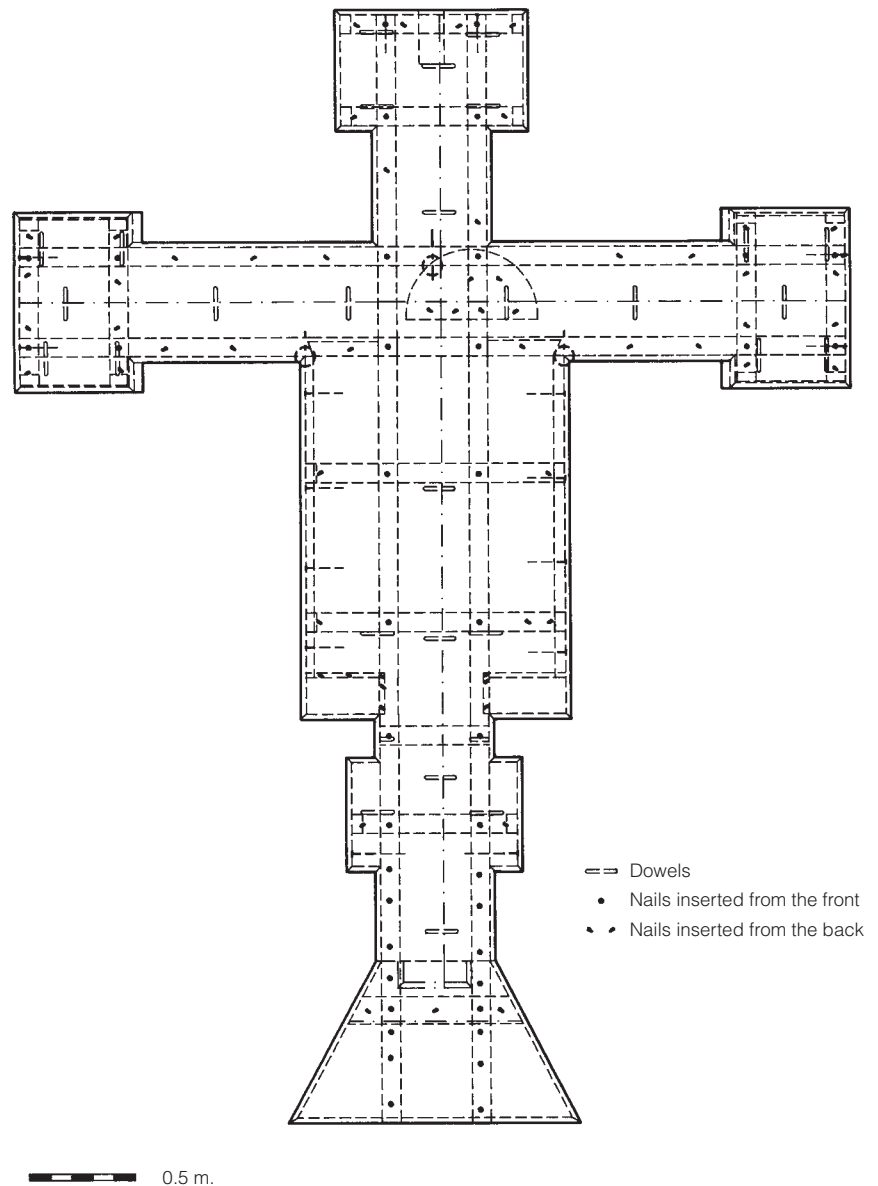

Figure 18

Wrought-iron nails typical of those used in supports.

Figure 19  
 Drawing showing the placement of nails in  
 Giotto's *Crocifisso di Santa Maria Novella*.



of rust. To ensure this, nail points were clinched deep into the wood. Nail heads, possibly embedded deeper than the wood surface, were separated from the ground layer by means of plaster, cloth, parchment, or—in the most careful constructions—wooden plugs.<sup>30</sup>

Here, however, as elsewhere, no definite rules apply. For instance, in Giotto's *Maestà*, although the whole support was conceived and made with the greatest care (Fioravanti and Uzielli 1992), several nail heads protrude on the front face, bulging through the cloth and ground layer, making clearly visible marks on the painted surface.

On some panels, lines for correctly aligning the nail holes may still be found, especially those that remained protected under a crossbeam and became visible only upon its removal. Obviously, such lines may be found only on the back side, since the ground layer deleted or made invisible those that might have been traced on the front.



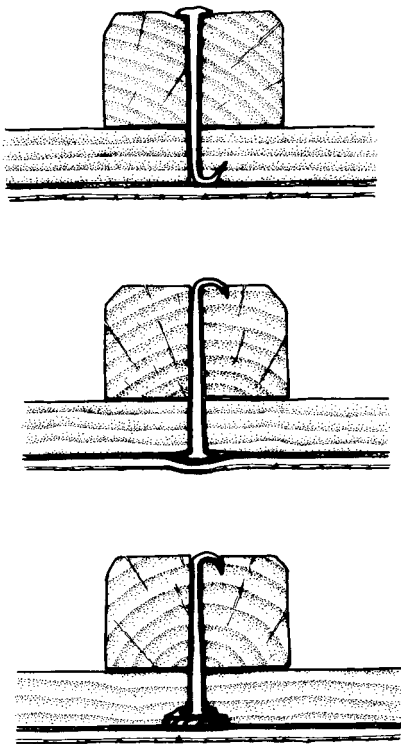

Figure 20, above  
 Drawings showing typical methods for clenching the nail point and insulating the nail head.

Figure 21, below  
 Beccafumi, *Madonna e santi*, reverse, detail. Collection of Chigi Saracini, Siena. Wooden bridge of a sliding crossbeam.

Figure 22, below right  
 Fra Angelico, *Annunciazione*. Convent of Montecarlo, San Giovanni Valdarno. Drawings of metal pins providing a sliding connection for a crossbeam.

### Sliding crossbeams

Many techniques for linking the crossbeam to the panel while allowing for some freedom of movement have been devised by the artisans who originally made these supports.<sup>31</sup>

Some sliding crossbeams were linked to the panel by means of metal bridges that were nailed or screwed on the back face, as in Botticelli’s *Primavera*. Other sliding crossbeams featured wooden bridges that were both nailed and glued to the panel, such as Beccafumi’s *Madonna e santi* (Fig. 21).<sup>32</sup>

An ingenious system based on iron pins fixed to the panel and passing through slots made in the crossbeam may be found in Fra Angelico’s *Annunciazione* (Fig. 22). The pinhead (along with many carefully applied nails) has been embedded lower than the front surface of the panel and protected by means of wood dowels. The distance between the crossbeam and panel is adjustable at the opposite end of the pin by means of small metal wedges.

Another system replaces bridges with a pair of beams appropriately shaped and nailed to the panel to serve as a guide for a sliding crossbeam with a trapezoidal cross section; an example of this system is the support of Matteo di Giovanni’s *Madonna e santi* (Fig. 23).

### Dovetailed crossbeams

Although they may be considered capable of “sliding,” dovetailed crossbeams are described here separately. Dovetailed crossbeams (Figs. 24, 25), which may have been derived from the technique traditionally used in icons, began to be widely used for panel supports starting in the early sixteenth century.

The dovetail joint ensures a positive grip between the panel and crossbeam, allowing the two elements to slide reciprocally but not to warp.<sup>33</sup> In addition, the resulting constraining forces are distributed evenly along the crossbeam, rather than being concentrated at specific points, as happens with nails or similar devices. Hence, there is a smaller risk of ruptures generated by concentrated stresses.<sup>34</sup>

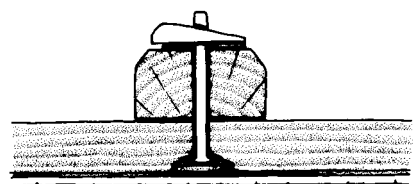
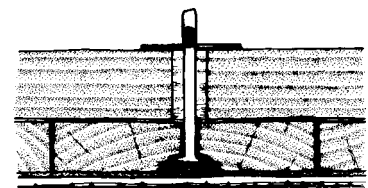
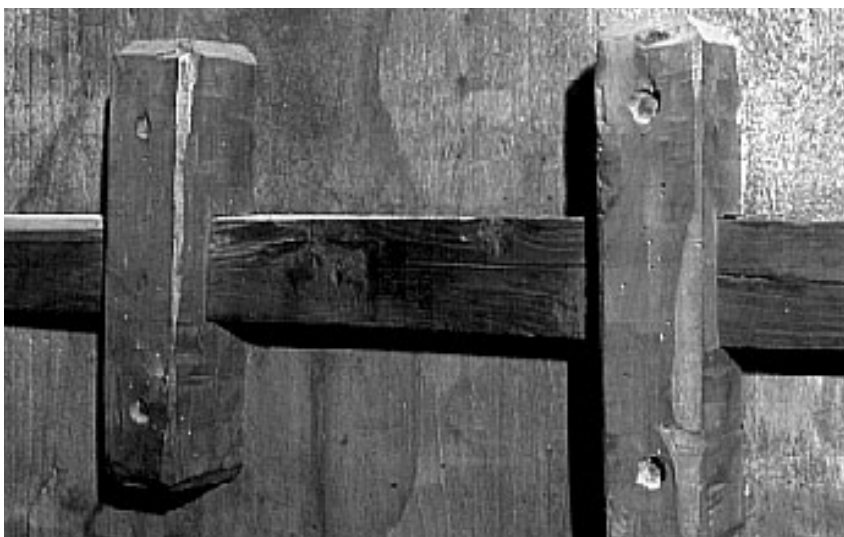

*Figure 23*

Matteo di Giovanni, *Madonna e santi*, reverse, detail. Cathedral of Pienza. Two wooden bars stabilize a rudimentary sliding crossbeam.



This type of crossbeam typically featured a trapezoidal cross section, inserted in grooves with a corresponding cross section forming a sort of dovetail joint (grooves are mortised across the grain into the planking, as deep as approximately one-third of its thickness).<sup>35</sup> This crossbeam type was also widely known to have a longitudinal taper, which made it possible to tighten the dovetail joint simply by displacing the crossbeam along its axis; adjacent crossbeams were placed with the larger ends oriented toward opposite edges of the support (Fig. 25).

### Glued crossbeams

Because glued connections are very stiff, two boards glued with their grain directions perpendicular to each other develop very high stresses in response to even small moisture changes. Therefore, glued crossbeams are seldom found. There are some cases, however, in which complex structures with cross-grain elements glued together behave fairly well over time.

### Interlocking crossbeams

In some cases, where distance, exceptional size, or other reasons would make transportation of large polyptychs from the workshop to the church too difficult, the painting would be made in sections for assembly in situ. For instance, Bomford and coworkers (1989) describe Ugolino di Nerio's altarpiece from Santa Croce, whose surviving fragments are scattered in

Figure 24

Schematic drawing of a typical dovetailed crossbeam with rectangular cross section.

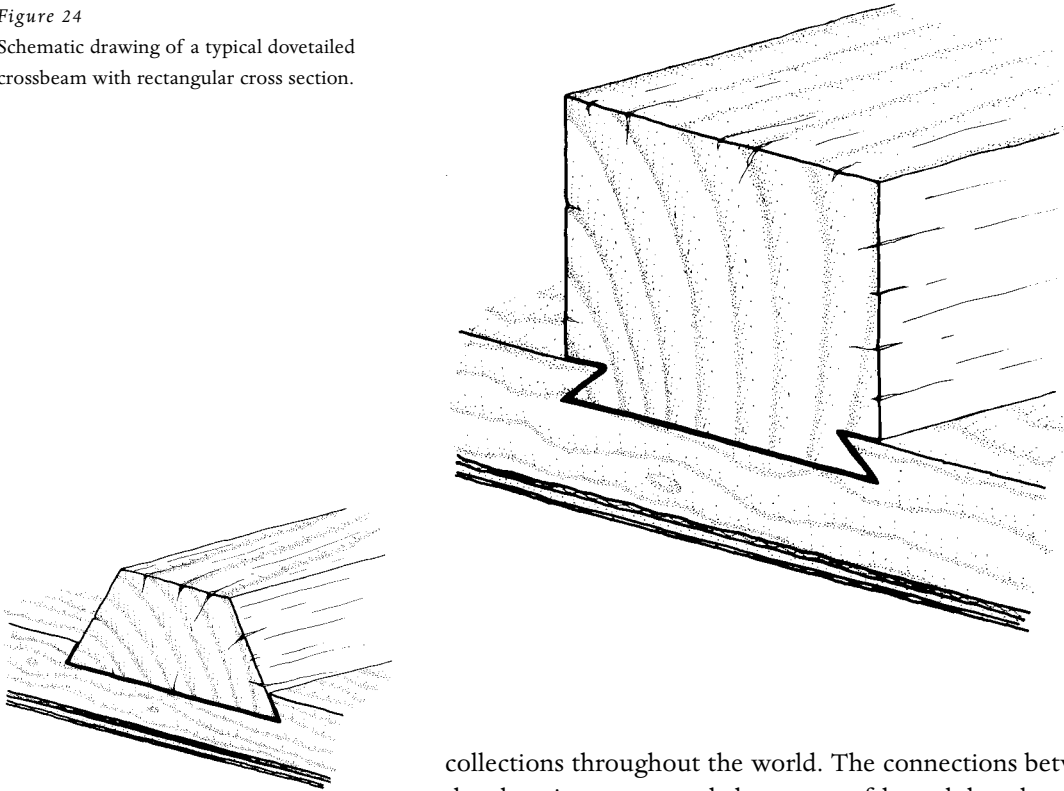

Figure 25

Schematic drawing showing typical fitting of dovetailed crossbeam with trapezoidal cross section. Crossbeams were often tapered to provide a snug fit.

collections throughout the world. The connections between the sections of the altarpiece were made by means of lateral dowels and an ingenious system of interlocking battens, possibly pegged with wood dowels (Fig. 26).<sup>36</sup> Two other rare examples of panels with intact, original, interlocking battens can also be cited: a small altarpiece by Bernardo Daddi, dated 1344 (Spanish Chapel, Santa Maria Novella, Florence), and a polyptych by Taddeo di Bartolo, dated 1411 (Pinacoteca, Volterra).

Figure 26

Ugolino di Nerio, fragments from the *Santa Croce Altarpiece*, National Gallery, London. Drawing showing the construction of a vertical unit of a polyptych.

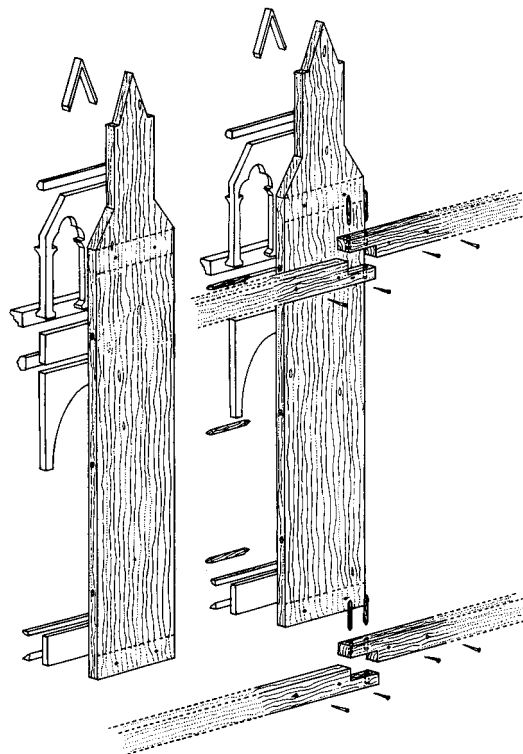

## The back side of the panel

While the back sides of many panels are often painted, finished, or treated in some way, the backs of others show no evidence of previous surface treatment or painting. This condition may have been a deliberate decision or simply a loss over time of the original treatment.

### Aesthetics of the back side

Some panels, particularly crucifixes, were decorated on the back side because they were intended to be seen from both sides because of their placement (on iconostases, for example) or use in religious ceremonies. With other panels, the back sides have been carefully finished and shaped, even though they probably were not intended to be as visible to the public as was the main painting. This treatment indicates an intention to create a work that would be lovely in itself.

Other panels were occasionally painted on both faces. In some cases, the two faces held the same “rank” (e.g., Beccafumi’s *Cataletto* or Duccio’s *Maestà* in Siena, which was sawn across its thickness in the eighteenth century). In other cases, the painting on the back face served more as decoration and was possibly made by another artist. Examples include Raphael’s portraits *Agnolo Doni* and *Maddalena Doni*, which bear monochrome paintings on their back faces, possibly by a disciple of Raphael; Piero della Francesca’s portraits *Federico da Montefeltro* and *Battista Sforza*, which bear the *Trionfi* on the back; and a large triptych (347 × 393 cm) by Rossello di Jacopo Franchi that bears a gesso ground layer on the back with a painted geometrical decoration simulating polychrome marbles, suggesting that it may have been part of a chapel (Dal Poggetto 1981). From the technological point of view, such double-face panels are more stable because of their mechanical and hygroscopic symmetry (Uzielli 1994). The crossbeams, if they exist at all, are confined at the periphery of the support and possibly include the frame, or they may simply be part of the decoration.

Some of the surface treatments of the backs of panels that are discussed below fulfilled an aesthetic function as well.

### Surface treatments of the back side

The back sides of panels were sometimes smoothed and treated with certain substances to obtain various results, which might have included the slowing of moisture exchange, protection from the accumulation of dust, preventive action against insects, or an aesthetic finish. As for other features of the supports, treatment of the backs (and of the edges of panels) was generally more frequent and careful in the earlier than in the later centuries.

A number of substances were used for treating the back face. These included a gesso grosso ground layer, which enhanced the symmetry between the two sides, hence improving dimensional stability and the flatness of the panel (Fig. 27). A superficial layer of red lead (i.e., minium-red tetroxide of lead that had both an aesthetic effect and a preservative action against insects) or white lead (basic carbonate of lead), with glue or oil used as binding agent, was also employed, as were earth pigments.<sup>37</sup>

It should be noted that the mixtures of waxes occasionally found on the back of some panels (penetrating the wood only up to a limited depth) have perhaps been applied in later conservation attempts.

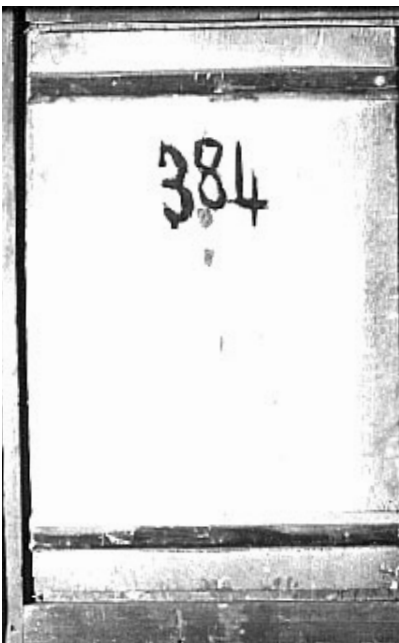

Figure 27  
Beccafumi, *Trinità della Trinità*, reverse, detail. Pinacoteca Nazionale, Siena. The back of a panel covered with the original gesso grosso ground.

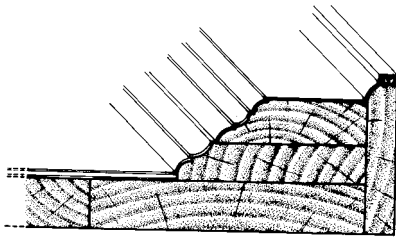

Figure 28  
Drawing showing cross section of an engaged frame. Duccio, *Maestà*.

## Engaged frames

When engaged frames served as integral parts of the support, the implications were structural as well as aesthetic (Cammerer 1990). Structurally, the engaged frame offered a substantial contribution both to the strength and rigidity of the support and to the lateral sealing of the panel. Such sealing in turn acted as a moisture barrier by slowing down rapid variations in humidity and protecting against the egg laying of wood-boring insects. The cross-sectional detail of the engaged frame of Duccio's *Maestà* shows how the thickness of the engaged frame is the result of two overlapping poplar moldings, while two outer moldings serve as lateral sealing (Fig. 28).

---

## Conclusion

Art-historical studies, technical analyses, conservation, and restoration should unite to further the understanding of works of art. Restoration presents an occasion during which this unity may be fully understood, because of the imperative yet apparently contradictory requirements to both respect and restore the original integrity of the work (Baldini 1992a). In this regard, it has been shown that collaboration among these various disciplines best serves the long-term interest of the work of art (Ciatti 1992).

An important attribute of today's artisans in Florence is their awareness of their connection with the artisans and artists who conceived and made the panel paintings in the Florentine *botteghe* so many centuries ago. Indeed, when faced with a particular problem, they often ask themselves, How would I have done this work or solved this technical challenge, had I *myself* been faced with the original problem? The concepts discussed in this article, therefore, owe a great debt to the past, as well as to the many restorers, artisans, art historians, and fellow scientists (truly good and experienced friends) who have contributed to the technological knowledge of panel supports outlined in this article. The author is indebted to more people than can be mentioned here, fellow Florentines who still maintain continuity with the great masters of our tradition.

---

## Acknowledgments

Among many others, the author wishes to mention Alfio Del Serra, restorer, who patiently and graciously offered the experiences of his rich working life during lengthy and fruitful discussions; Ornella Casazza of the Uffizi Gallery, Florence, art historian and former restorer; Marco Ciatti, Ciro Castelli, and their numerous coworkers in the Restoration Laboratory of the Opificio delle Pietre Dure, Florence, who also greatly contributed to this article through engaging discussions (often at the "bedside" of artworks under restoration); Umberto Baldini, internationally known art historian and curator; Orazio Ciancio, Gabriele Bonamini, Marco Fioravanti, Giovanni Hippoliti, Martino Negri, Franco Piegai, Lorenzo Vedovato, and Rosalia Verardo, from the University of Florence; Stefano Berti and Anna Gambetta from the Italian National Council for Research (CNR) Istituto per la Ricerca sul Legno, Florence; Elio Corona from the University of Viterbo; Franco Lotti from CNR-IROE, Florence. The author also wishes to acknowledge Renzo Turchi, Giovanni Cabras, Renato Castorrini, and Barbara Schleicher, restorers, from whom he gained deep insights about wooden artworks and restoration techniques; Gianni Marussich, "ancestor" of many restorers, who has performed his work on both sides of the Atlantic from Florence to Malibu; Anna Maria

Petrioli Tofani, director, and the whole staff of the Uffizi Gallery, for making possible his research at the Uffizi; Giorgio Bonsanti, superintendent of the Opificio delle Pietre Dure, and Antonio Paolucci, Italian minister for the Arts and the Environment, for their continuing support; Sergio Zoppi, Angelo Guarino, Piero Manetti, Mauro Bacci, and other members of the Committee for Cultural Heritage of the CNR, whose financial support made these activities—and hence this report—possible. The author also thanks his wife, children, and parents, for their patient support during the many weekends and holidays he dedicated to this work.

The research on which this article is based was made possible by the financial support of the following institutions: Progetto Strategico Beni Culturali and Progetto Strategico Uffizi, funded by the CNR; and “Fondi 60%,” from the University of Florence and the Italian Ministry for University and Research (MURST).

---

## Notes

- 1 Marette (1962) considers that with regard to the study of panel supports, peninsular Italy may be divided into eight main areas: central Italy (Umbria and Foligno), Emilia-Romagna (Bologna, Modena, and Ferrara), Florence, Marche, Pisa-Lucca, Rimini, Rome, and Siena. In this context, the numerous towns and workshops, or *botteghe*, in central Italy (which includes present-day Tuscany, Umbria, Marche, and Latium) may have been most influenced by the techniques developed in Florence and Siena.
- 2 In Giotto's *Crocifisso di Santa Maria Novella*, the cloth glued on the panel is coarser than the one glued on the engaged frame, the latter being thinner so as to better follow the molding (Bracco, Ciappi, and Ramat 1992).
- 3 The three main species of poplar—white poplar, *Populus alba* L. (Italian: *pioppo bianco*, *gàttice*, *alberaccio*); European aspen, *P. tremula* L. (Italian: *pioppo tremolo*, *alberello*, *fàrfaro*); and black poplar, *P. nigra* L. (Italian: *pioppo nero*)—as well as several hybrids, have been present throughout Italy since ancient times. The presently cultivated poplars are mostly hybrids, such as *Populus euramericana* [Dode] Guinier, derived from crossbreeding with North American black poplars imported to Europe in the eighteenth century.  
The Lombardy poplar (*P. nigra* cv. *italica* Du Roy = *P. pyramidalis* Roz [Italian: *pioppo cipressino*, *pioppo piramidale*]) is a clone of *P. nigra*, which apparently originated through a spontaneous mutation. This clone is frequent in northern Italy (hence its English designation, Lombardy poplar), and since male individuals are the vast majority, it is propagated only from cuttings. The woods of all these poplar species are quite similar and cannot be distinguished by anatomical examination. However, it is likely that most boards used for panel making were obtained from *P. alba*, which generally produces wood of better quality.
- 4 Marette reports data and statistics for more than 1800 panel paintings from various museums (Marette 1962). Gettens and Stout give a summary of woods made from the catalogues of the Munich and Vienna museums, with a few items from the catalogue of the National Gallery, London (Gettens and Stout 1966).
- 5 The microscopical identifications were performed by the author's late colleague Prof. Raffaello Nardi Berti (Nardi Berti 1984).
- 6 Cupping is a particular kind of warping caused mostly by anisotropy of shrinkage—that is, by greater shrinkage in the tangential direction than in the radial (Buck 1962, 1972; Thomson 1994; Uzielli 1994).
- 7 Castelli and coworkers state, however, that exclusive use of radially sawed boards was typical of the most careful works (Castelli, Parri, and Santacesaria 1992).
- 8 The pith is seldom perfectly straight in poplar logs, so it seldom affects the whole length of the diametric board. Furthermore, its occurrence (although constituting a zone of weakness, occasionally generating longitudinal fissures) will not necessarily imply a dramatic and complete separation in the board.

- 9 According to Castelli and coworkers, such a choice may be explained by the fact that wood placed nearer to the pith (possibly assumed to coincide with the heartwood) was considered to be of better quality. As a consequence of seasoning, since the cupping convexity becomes oriented toward the “inner” face, the application of the ground to that face should ensure a better “grip” (especially during its application, when its high water content makes the wood swell and then dry again) (Castelli, Parri, and Santacesaria 1992).
- 10 Defects produce local differences in shrinkage that often result in greater damage to the painted layer in their vicinity. Because local wood defects were seldom a direct cause of a general or widespread deterioration of a painting support, the acceptance of boards with some localized defects may have been a reasonable choice, considering that negative effects could be prevented easily by appropriate techniques (e.g., the gluing of a layer of cloth between the boards and the gesso).
- 11 Because of obvious geometrical relationships, if the “inner” face of the board is oriented toward the painted face, wane will appear on the rear face. If, on the contrary, the growth rings are oriented so that wane is toward the painted face, the wane will need to be “repaired.”
- 12 The presence of sapwood may not be considered a defect in itself, especially in species in which heartwood is not distinct, such as poplar, linden, and fir.
- 13 For instance, Del Serra stresses this possibility for the support of Cimabue’s *Maestà* (Del Serra 1994). Many Florentine panel restorers use the expression *legno frolo* (“tender wood”) to describe partially decayed wood. This expression applies to the early stages of fungal decay, during which the strength properties of the wood are only moderately affected, while shape is retained and hygroscopic stability is higher.
- 14 According to established experience (which is basically the same today as during the Renaissance), good natural seasoning practice may require years for boards to reach a satisfactory absence of moisture gradients and settling of internal stresses. The specific number of years required varies with wood species and their particular permeabilities.
- 15 This is supported by the fact that given the typical climate in the area, natural seasoning (i.e., the traditional drying process, by which boards are stacked and left exposed to natural environmental conditions) would have hardly produced a lower EMC. Lower EMC values (around 10%) reached by the paintings that were later kept in heated buildings (after transfer to heated houses or museums, or after heating plants were installed in their original locations) usually led to severe shrinkage (Uzielli 1994).
- 16 When a support is exposed to humidity fluctuations, a greater thickness of boards contributes to its dimensional stability, since the consequent MC fluctuations in wood are slowed down (damped) by the time required for moisture to move into the deeper layers.
- 17 In many cases, the current thickness of boards differs from the original one. This difference is due to thickness reduction for cradling, rebacking (usually in the case of severe wood decay, or to remedy the warp), sawing along the central plane to obtain two separate paintings from a double-faced panel, or other kinds of intervention, intended either for conservation or for cosmetic purposes.
- 18 During recent restoration works performed by Del Serra in 1993–94, the rear surface of Cimabue’s *Maestà* (226 × 387 cm) was found to be cambered (cylindrically shaped), measuring 58 mm thick along its central longitudinal axis and growing progressively thinner in a symmetrical fashion to the two lateral edges, 40 mm thick. This shape is clearly the result of the original manufacturing process, since—after removal of the nineteenth-century crossbeams—there were a number of features to indicate that the present surface is the original one, including some remnants of a possibly original red tempera on the surface and red lines made with the string-snapping technique across the panel width, marking the alignment of the nails that connected the original crossbeams.
- 19 Such a rare feature is characterized by boards becoming progressively thinner from the center to the lateral edges of the panel; it should not be mistaken for the beveled edges that appear frequently in Flemish panels (typically made of radially cut oak boards and thinner than the Italian panels) and that are intended to allow for an easier fitting of the panel within its frame.
- 20 In some instances, the edging process might leave some wane, particularly when there was a need to take advantage of the maximum possible width of the board.

- 21 Tack is the property (present in some modern vinyl resin adhesives but not in casein glues) that holds the parts to be joined together while the adhesive is still fresh.
- 22 Many observations of disassembled supports, as well as expert opinion, confirm that splines fulfilled an alignment function only and were not intended to support or reinforce the connection.
- 23 X-shaped cleats (*tasselli a doppia coda di rondine*, “double dovetail cleats”; or *farfalle*, “butterflies”) were usually mortised into the boards as deep as one-half of the board’s thickness, with their grain running crosswise to the board’s grain, to hold adjacent boards or parts of a fissured board tightly together.
- 24 In polyptychs, predelle were often painted on horizontal boards, whereas other sections were on vertical boards; polyptychs should not be considered as single panels, however.
- 25 On the contrary, Bomford and coworkers report two relatively small painted crosses made from vertical boards by the Master of Saint Francis. The work (92.1 × 71 cm) in the National Gallery, London, was cut from a single plank of poplar, whereas the side terminals of the one in the Louvre were constructed separately and then attached with wooden dowels (Bomford et al. 1989).
- 26 The need to “hold together” the panel does not exist only while it is on display and therefore subject to the stresses imposed by its own weight and other internal or external static stresses. Other situations—such as transport, earthquakes, explosions, etc.—may impose exceptional stresses on panels. Del Serra describes damages, possibly due to transportation, found on Duccio’s *Maestà* (Del Serra 1990).
- 27 Nailed joints do not behave in the way that some widespread but incorrect ideas suggest. Joints perpendicular to the nail axis may yield significantly, both because of bending of the nail shaft and because of the give of the wood (low strength perpendicular to the grain). When appropriately clinched, however, they will resist large pullout forces. Thus, nailed crossbeams restrain somewhat the transversal shrinkage and swelling of the panel and at the same time prevent it from warping (detaching from the crossbeam) (Uzielli 1994).
- 28 Preboring of nail holes was carried out in at least the first of the two parts to be joined, in order to to guide the slender nail correctly (the nail was prone to deformation, especially at its thinner point) and to prevent fissures from forming in the seasoned wood.
- 29 Even though evidence shows no general rule, Castelli and coworkers report that two or three nails could be driven into each board, depending on its width. Nails could be either inserted from the back, in the more complex back frames such as the “lattice structures” of large crucifixes and altarpieces, or inserted from the front, in polyptychs; in some supports, the crossbeams were placed along the edges (making it possible to cover nails on the front face with engaged frames and predelle) (Castelli, Parri, and Santacesaria 1992).
- 30 Wooden plugs and plaster proved to be the best insulation against rust, since neither parchment nor cloth proved able to block rust. Parchment also proved to be an unstable basis for the ground layer.
- 31 See Buck 1972; Castelli, Parri, and Santacesaria 1992; and Uzielli 1994, among many others. The use of sliding crossbeams rather than nails is an attempt to provide adequate freedom for the panel to undergo shrinkage and swelling without generating concentrated and potentially harmful stresses.
- 32 Glued joints are stiffer; nailed joints are more yielding. If a joint is both glued and nailed, during its normal working life it will not differ from one that has been glued only; the presence of nails will not increase strength or stiffness.
- 33 Even more than in the case of the “sliding” crossbeams, the property of sliding applies for only a limited number of the dovetailed crossbeams. In fact, the higher contact pressure produced by the inclined walls of the dovetail and by the longitudinal taper generate even higher friction, which opposes sliding.
- 34 Obviously such action will hold only as long as the edges of the mortised groove—the weakest part of the system—are not damaged by insect galleries, decay, or pure mechanical stress. Evidence shows that many of these grooves, whether original or made during later restora-



tion, are much more damaged along the upper margin, possibly because of fungal decay associated with the accumulation of dust and the condensation of moisture.

- 35 In exceptional cases, a longitudinal distortion (bow) that increases as the MC of the wood decreases may be produced in the panel by forces exerted by the crossbeam along the panel's length (Allegretti et al. 1995).
- 36 The terms *crossbeam* and *batten* are synonymous. Bomford and coworkers use the term *cross-batten* (Bomford et al. 1989).
- 37 A few examples include Giotto's *Maestà* and *Crocifisso di Santa Maria Novella* and Cimabue's *Maestà*, which still show the remains of red color; in the case of the latter, the red color remnants (possibly an earth pigment) were instrumental for reconstructing the size and location of the no-longer-existing cradle. Another example is Leonardo's *Adorazione dei Magi*, which is coated so thickly with white lead on the back face that an X-ray inspection of the artwork proved impossible (Baldini 1992b).

---

## References

- Allegretti, O., P. Bertini, O. Casazza, M. Fioravanti, and L. Uzielli  
1995 Dimensional stability of the wooden support of a Middle Age panel painting: Laboratory tests on the influence of the cross-beams. In *Proceedings of the Conference on Science and Technology for the Safeguard of Cultural Heritage in the Mediterranean Basin*. Organized by CNR-Catania (Italy), 27 November–2 December.
- Baldini, U.  
1992a Dieci anni, e ancora questioni di metodo. In *Problemi di restauro—Riflessioni e ricerche*, ed. M. Ciatti, 9–11. Florence: EDIFIR.
- 1992b *Un Leonardo inedito*. Florence: Università Internazionale dell'Arte.
- Basile, E. I.  
1990 Tecniche di costruzione e metodi di trattamento dei supporti lignei. In *I supporti nelle arti pittoriche*, ed. C. Maltese, 317–419. Milan: Mursia.
- Bernacchioni, A. M.  
1992 Le botteghe di pittura: luoghi, strutture e attività. In *Maestri e botteghe—Pittura a Firenze alla fine del Quattrocento* (catalogue of the exhibition "Celebrazioni del V centenario della morte di Lorenzo il Magnifico," Florence, 1992–93), 23–34. Florence: Silvana Editoriale.
- Bomford, D., J. Dunkerton, D. Gordon, and A. Roy.  
1989 *Art in the Making: Italian Painting before 1400*. London: National Gallery.
- Bracco, P., O. Ciappi, and A. Ramat  
1992 Appunti sulla pulitura dei dipinti e prime note sul restauro della Croce di Giotto di Santa Maria Novella. In *Problemi di restauro—Riflessioni e ricerche*, ed. M. Ciatti, 109–23. Florence: EDIFIR.
- Buck, R. D.  
1962 Some applications of mechanics to the treatment of panel paintings. In *Recent Advances in Conservation*, ed. G. Thomson, 156–62. London: Butterworths.
- 1972 Some applications of rheology to the treatment of panel paintings. *Studies in Conservation* (17):1–11.
- Cammerer, M.  
1990 La cornice della "Madonna Rucellai." In *La Maestà di Duccio restaurata*, 47–55. Gli Uffizi—Studi e ricerche, no. 6. Florence: Centro Di.

- Castelli, C., and M. Ciatti  
1990 I supporti lignei dei dipinti e i sistemi di traversatura: Un'analisi storica e alcune proposte operative. In *Il restauro del legno*, vol. 2., ed. G. Tampone, 141–54. Florence: Nardini Editore.
- Castelli, C., M. Parri, and A. Santacesaria  
1992 Supporti lignei: problemi di conservazione. In *Problemi di restauro—Riflessioni e ricerche*, ed. M. Ciatti, 41–63. Florence: EDIFIR.
- Cennini, Cennino d'Andrea  
1994 *The Craftsman's Handbook*. Trans. Daniel V. Thompson Jr. Originally published as *Il libro dell'arte*, ca. 1437. New York: Dover Publications.
- Ciatti, M.  
1992 La conservazione dei dipinti oggi: Problemi, metodi e risultati. In *Problemi di restauro—Riflessioni e ricerche*, ed. M. Ciatti, 13–23. Florence: EDIFIR.
- Ciatti, M., and C. Castelli  
1994 Esperienze di intervento sui supporti lignei. In *Conservazione dei dipinti su tavola*, ed. L. Uzielli and O. Casazza, 47–72. Florence: Nardini Editore.
- Dal Poggetto, P.  
1981 Intervento a un dipinto su tavola di Rossello di Jacopo Franchi. In *Atti del Convegno sul restauro delle opere d'arte* (Florence, 2–7 November 1976), ed. A. M. Gusti, 145–49. Florence: Opificio delle Pietre Dure e Laboratori di Restauro di Firenze, Edizioni Polistampa.
- Del Serra, A.  
1990 Il restauro del supporto ligneo. In *La Maestà di Duccio restaurata*, 57–63. Gli Uffizi—Studi e ricerche, no. 6. Florence: Centro Di.  
1994 Communication with the author.
- Filippini, C.  
1992 Riquadrature e “restauri” di politici trecenteschi o pale d'altare nella seconda metà del Quattrocento. In *Maestri e Botteghe—Pittura a Firenze alla fine del Quattrocento* (catalogue of the exhibition “Celebrazioni del V centenario della morte di Lorenzo il Magnifico,” Florence, 1992–93), 199–218. Florence: Silvana Editoriale.
- Fioravanti, M.  
1994 Le specie legnose dei supporti: Implicazioni per la conoscenza, la conservazione ed il restauro dei dipinti su tavola. In *Conservazione dei dipinti su tavola*, ed. L. Uzielli and O. Casazza, 83–108. Florence: Nardini Editore.
- Fioravanti, M., and L. Uzielli  
1992 Il supporto ligneo. In *La Maestà di Giotto restaurata*, 105–18. Gli Uffizi—Studi e ricerche, no. 8. Florence: Centro Di.
- Gambetta, A.  
1994 Attacchi biologici: Lotta e prevenzione. In *Conservazione dei dipinti su tavola*, ed. L. Uzielli and O. Casazza, 73–82. Florence: Nardini Editore.
- Gardner von Teuffel, C.  
1983 From polyptych to pala: Some structural considerations. In *La pittura nel XIV e nel XV secolo: Il contributo dell'analisi tecnica alla storia dell'arte* (Atti del XXIV Congresso C.I.H.A., 1979), ed. H. W. van Os and J. R. J. van Asperen de Boer, 323–44. Bologna: CLUEB.

- Gettens, R. J., and G. L. Stout**  
1942–66 *Painting Materials. A Short Encyclopedia.* (1942: Van Nostrand Company, Inc.; 1966: Dover Publications Inc., New York, N.Y.)
- Giordano, G.**  
1988 *Tecnologia del Legno.* Vol 3. Torino: UTET.
- Marette, J.**  
1962 *Connaissance des primitifs par l'étude du bois.* Paris: Picard.
- Nardi Berti, R.**  
1984 Schede diagnostiche. In *Raffaello a Firenze. Dipinti e disegni delle collezioni fiorentine*, 241–70. Milan: Electa Editrice.
- Schweingruber, F. H.**  
1990 *Anatomy of European Woods.* Bern and Stuttgart: Verlag Paul Haupt.
- Thomson, G.**  
1994 *The Museum Environment.* Oxford: Butterworth-Heinemann.
- Uzielli, L.**  
1994 Danni causati ai dipinti su tavola da variazioni termogrometriche, e loro prevenzione. In *Conservazione dei dipinti su tavola*, ed. L. Uzielli and O. Casazza, 109–49. Florence: Nardini Editore.

# Wooden Panels and Their Preparation for Painting from the Middle Ages to the Seventeenth Century in Spain

Zahira Véliz

**S**PANISH TECHNIQUES in the plastic arts possess a pedigree unique in western Europe. In Spain the technology of movable works of art, architecture, and urban planning was influenced by the legacy of Islamic culture as well as by practices and traditions originating in Italy and the Gothic North. Islamic prohibitions on recognizable images meant that Muslim artisans understandably had little impact on painted images; even so, the methods of joinery and traditional understanding of wood manifest in Islamic architecture and decorative arts surely informed the techniques evident in painted panels and altarpieces. The climate and materials indigenous to the Iberian Peninsula also affected panel making. This article will discuss the technology of wooden panels and their preparation for painting in Spain from 1400 to 1700 C.E. Contracts and other documents from this period are cited.<sup>1</sup>

---

## Contracts

Perhaps more than elsewhere, retables in Spain (with their integral panels or sculptures) were produced as corporate enterprises. Contracts were often complex documents with subcontracting specifications. Included were the dimensions, type of wood, iconographical subjects, price, time limits, and terms. It was common practice for a master painter to undertake responsibility for all aspects of a large job that he might subsequently subcontract to other specialists. In some cases, there is evidence that even the painting of panels was divided between two different workshops (Navarro Talegón 1984:330). Occasionally the job carried a warranty: “Item, it is agreed that if by chance the retable or part of it loosens [from the wall] or sustains any damage from being badly installed, if for some reason that is the fault of the painters, that they are responsible for damages during six years from its installation if the painters [guild officials] declare that it is needed” (Serrano y Sanz 1914:447).

Clearly, using top-quality materials and techniques was important in a legal climate where such statutes were known, even if they were not actually commonplace. Nevertheless, damage did occur, and when the original artists were no longer available, other painters would turn their hands to restoration, as did the Catalan painter Francesc Feliu, who in 1412 “patched cracks, touched up faded colours, and repaired Jesus’s mantle” in the retable of the chapel of All Saints in Santa Maria of Manresa (Sobré 1989:46, n. 59).

The carpentry of the panels and retables was executed in several ways, and local custom varied slightly. In Aragon the carpentry was often carried out in the artist's studio. Elsewhere it was finished prior to the painter's contract (Sobré 1989:35). Separate contracts for painting and carpentry were also frequent, as was the widespread practice of subcontracting the carpentry. In most situations, one can assume that the painters had considerable say about the standards to which their panels would be prepared. The importance given to the quality of work at this stage is underscored by a clause in a contract dated 1561: "Item that [they] are obliged to show all the pieces of the altarpiece once they are worked and clean and prior to applying any colour to any piece, and this is done so that persons named by [the client] can see the work" (García Chico 1946:95).

---

### Woods Used for Painting Support

Wooden panels in Spain, as in other western European countries, were made principally from locally available woods, although, of course—considering the active political and commercial contacts with the Low Countries—panels were fairly frequently imported. Within Spain regional characteristics become evident, with pine predominating in Castile and Aragon, poplar in Catalonia. Walnut is found occasionally in Castilian panels, as is (much more rarely) Spanish oak. The use of thuja (red or white cedar, also the source of sandarac) in Europe seems unique to the southern quarter of the Iberian Peninsula. There is one documented example of Flemish oak having been imported for a specific commission, Lluís Dalmau's *Virgin of the Councillors* (Sobré 1989:51, 288–91). Many panel paintings of the school of Viseu in Portugal are painted on chestnut (Marette 1961:52–53, 67–69). Contracts reflect practical concern for the quality and suitability of the wood—its hardness, ease of working, and freedom from knots, veins, stains, and other defects. The importance of the commission and the client's wealth also influenced the type and quality of wood employed.

The age and dryness required of the wood for retables and panels is frequently specified in the contracts: the retable "must be dry pine from Soria, good and dry, and the figures and columns of wood from Ontalvilla and the said wood must be dry pine from Soria as is said, dry for at least six years" (García Chico 1946:156). In Castile "pine from Soria" is often mentioned, and sometimes exact localities are named, such as Ontalvilla, Cuéllar, San Leonardo, or Quintanar de la Sierra. Occasionally wood from distinct sources is designated for different purposes: "[The architecture] should be of pine wood from Soria, dry and good . . . and the histories [panels?] and sculptures can be of local pine" (García Chico 1946:73). Occasionally even the time of cutting is stipulated, as occurs in a contract of Gregorio Hernández for the construction of the high altar retable of Las Huelgas Reales in Valladolid: "It is a condition that all the wood for the said sculpture must be from Ontalvilla, dry and clean, free of knots, white, not dark wood, and cut in a good moon" (García Chico 1946:160).<sup>2</sup>

---

### Panel Construction

Once the appropriate wood was selected, the assembly of the panels proceeded in a variety of ways. Although most panels of any size were usually joined, the following passage indicates the desirability of single-member

panels: “All the retable must be made of walnut and no other wood, and the walnut must be good, dry, and having been cut for as long a time as possible, clear of knots, even if it must be brought from outside Valladolid. . . . And the histories and saints must be made of single pieces . . . should joins be unavoidable, they must be as few as possible for the greater perpetuity of the work” (García Chico 1946:86).

The planks, whether destined to be joined or used as single-member panels, were cut, sawn, and planed with considerable thickness, 3–4 cm being quite common. On the reverse of many panels, the marks left by the planes and gouges are still apparent. The most common joins were butt joints, apparently sometimes without a glue adhesive between the panel members (*juntas vivas*). Butt joints are frequent in panels from the fourteenth to the seventeenth century (Prieto Prieto 1988:201). Concern about the long-term stability of panels joined in this way must have prompted the practice of reinforcing the join. The simplest method was caulking or plastering over the joins with the filling compound used to make good any uneven places on the wood surface, pressing it through gaps in the joins and forming a ridge at the reverse of the panels, effecting a kind of solder (Fig. 1). This procedure was considered so important that standards about panel preparation were included in the *ordenanzas* (ordinances governing civic guilds and commerce) of Cordova (1493) (Ramírez de Arellano 1915:25–36) and mentioned as well in the *ordenanzas* of Granada (early sixteenth century) and Seville (1632).<sup>3</sup> The earliest text from Cordova is the most specific: “It is further ordered and required that the retables of painted panels should be worked in such a way that all the joins of the panels, and any other cracks whatsoever are caulked<sup>4</sup> and afterward well primed with parchment glue. This glue must be made by a master who has great knowledge in its temper and cooking because it must be very well tempered and heated in the right way” (Ramírez de Arellano 1915:38).

Figure 1  
A pine panel prepared for painting in Castile.

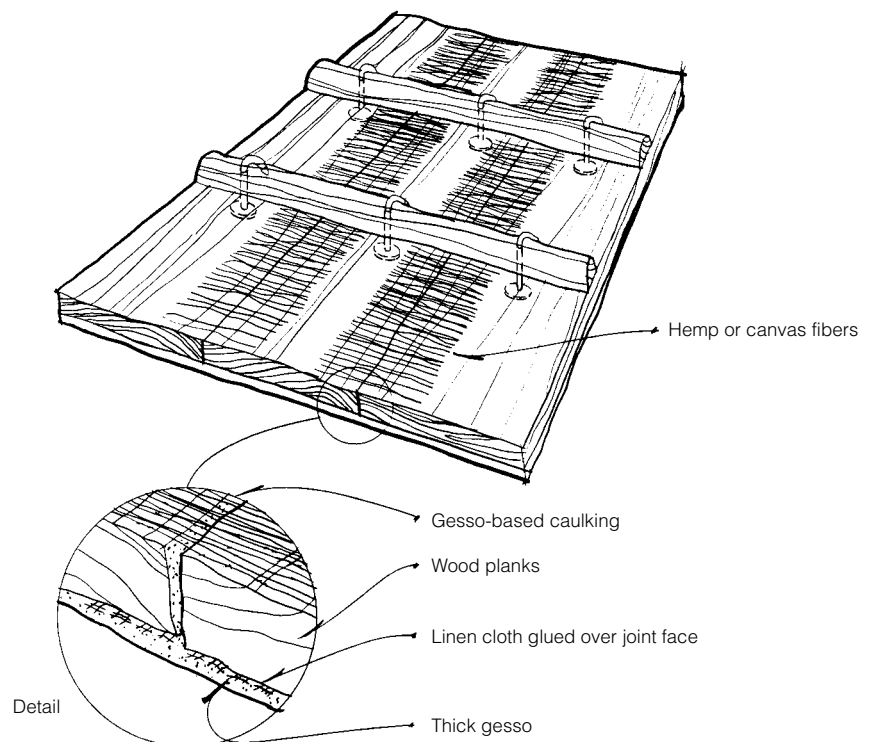

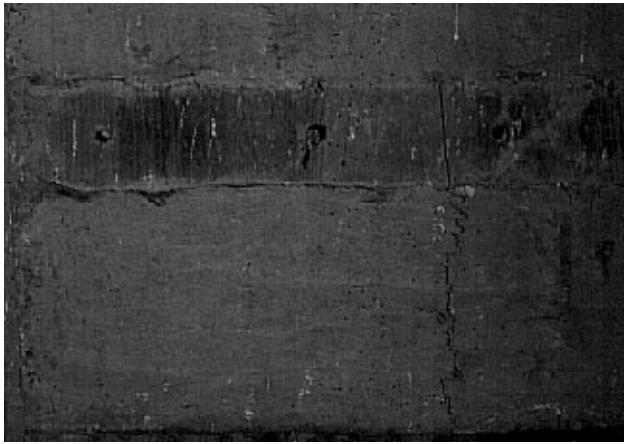

Figure 2, above

Luis de Castilla, *Crucifixion of Saint Andrew*, ca. 1530. Reverse. Oil on panel, 120 × 140 cm. San Lorenzo el Real, Toro, Zamora, Spain. The use of dowels to affix the crosspieces is shown.



Figure 3, above right

Anon., ca. 1580, reverse. Oil on panel. Toledo, Spain. A crossbar engaged in a channel across the grain direction on the back of a pine panel. Randomly applied hemp or flax fibers are visible.

In addition to the universally popular butt-joined panels, dowelled joints, butterfly lap joints, and plain lap joints have been noted (Prieto Prieto 1988:270; Marette 1961:52–53, 67–69), although sound technical studies of Spanish panels are scarce, and the works documented so far form a largely haphazard sample.<sup>5</sup>

Most Spanish panels are reinforced by crossbars and additionally by the application of canvas or vegetable fibers (such as esparto grass) and gesso to either side or both sides of the panel. These materials are used in combination or separately and will be discussed below.

It is fair to surmise that crossbars (*travesaños*) were recognised as important to the long-term stability of the panels as they are frequently mentioned in the contracts: “It is a condition that the painting must be on the church’s account . . . and [the church] must provide the panels with their crossbars” (García Chico 1946, vol. 2:312). “Furthermore, the wood must be of good quality . . . the panels will also have good crossbars . . . and [the panels] will be well fixed and maintained by them” (Madurell Marimón 1946:151). In the simplest method, crossbars on the reverse of the panels are fixed by nails pounded through from the face in a cross-grain direction and clinched against the back surface of the crossbar. Very common also was the use of dowels to hold the crossbars to the panels, sometimes in addition to nailing. A variant of this method provides a shallow channel in the reverse surface of the panels that engages the crossbar (Figs. 2, 3).

The use of two to three simple crossbars is most typical of Castile (Fig. 4). From the final third of the fourteenth century, more complex

Figure 4

Anon., ca. 1540, reverse. Oil on pine panel. Church of San Lorenzo, Toro, Zamora, Spain. Heavy crossbars secure the vertically joined pine planks. Esparto grass fibers cover the joins.



crossbar arrangements, such as diagonal crosses or grids, were common in Aragon, Catalonia, and Valencia, especially for large panels or panels meant to be viewed as a series (Figs. 5, 6). In Valencia a single horizontal crossbar secured the center of the panel, with additional planks radiating, spoke fashion, above and below it. In Aragon a central vertical bar was flanked by several symmetrical horizontal members (Sobré 1989:52).

## Additions to the Panels

Although reinforcements such as linen or hemp (cloth or fibers), with or without gesso, are known in all European schools of painting, these materials are most abundant in the preparation of Spanish panels. Linen, like hemp, can be found on both the face and the reverse of panels. When used on the face, it is not infrequent to find the entire surface of the panel covered, while on the reverse it is normally applied in strips to bridge a join. Hemp cloth, similar to burlap, is used in the same way. It is also common to find coarse hemp or flax fibers (*estopa*), sometimes applied across joins only and sometimes distributed in an even, multidirectional layer over the entire face (or, indeed, reverse) of the panel prior to the application of gesso.<sup>6</sup>

The contracts are specific about the use of the additional reinforcements as part of the preparation of the panels for painting. In 1518 the painter Pedro Núñez signed a contract in which he promised to make the retable of wood: "All of it will be caulked [*plastecido*], and the joins will

Figure 5, below  
Maestro de Torá, *Three Saints*, early fifteenth century. Oil on panel.

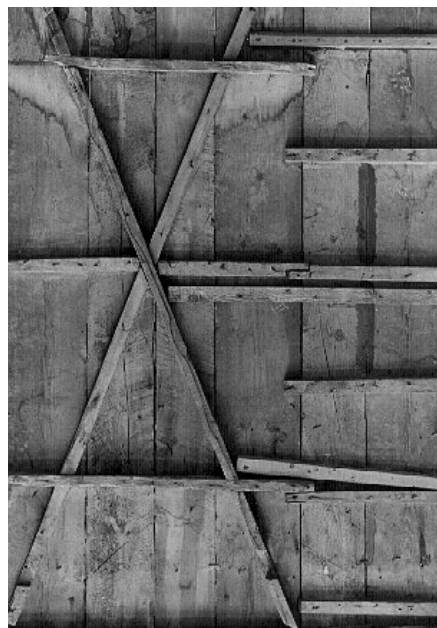

Figure 6, above  
Maestro de Torá, *Three Saints*, reverse. The two donor panels are joined together by reinforcing crossbars (diagonal and horizontal) nailed through from the front of the panels prior to painting. The painted panels are fitted together vertically by lap joins and by means of the notched horizontal crossbars.



be covered with linen wherever it shall be needed” (Madurell Marimón 1944:155, 166, 205). In 1570 a contract between a patron and the painter Juan Tomás Celma states that “firstly, the said Juan Tomás and his wife promise that they will cover and reinforce with hemp and linen all of the gaps and fissures to be found when the wood of the said retable is worked, and where necessary over the joins, and then they will prepare [the pieces] with all care and tidiness and delicacy” (García Chico 1946:166). Two further brief references clarify, first, that the canvas was applied to the panel after the first glue priming: “After one application of glue to all the wood, the joins and splits must be covered with strips of linen and strong glue [*cola fuerte*, carpenter’s glue],” and, second, that canvas strips should be applied to the joins with *cola fuerte* in the altarpiece of Santa Cruz in Medina de Rioseco, because “it is necessary so, because only caulked, [the joins] are not secure” (García Chico 1946:372, 154).

It is impossible at present, on either empirical or documentary evidence, to determine a preference for grass fibers or woven cloth for covering joins or knots or other faults in the panel. However, it can be affirmed that in contracts, linen is mentioned more frequently for use on the face and hemp fibers for use on the reverse. Personal preference on the part of the artist, as well as local custom, seem to have been the determining factors.<sup>7</sup>

Francisco Pacheco, whose seventeenth-century treatise *El arte de la pintura* (Pacheco 1965) is one of the most useful sources for Spanish painting techniques, writes on these measures with some critical perspective. In the seventeenth century the use of panels in Spain, as elsewhere, was diminishing. His comments are far more informative than the tersely worded contracts:

Nowadays gilders avoid covering the openings and joins between pieces of wood used for architecture and sculpture because it seems to them that nothing can be done to prevent the wood from opening. At first glance, the use of linen pieces seems to be unnecessary, but I will state my feeling about this, telling the truth as I see it. It is certain that painters before our time had great interest in preparations and gilding, as is seen in many of their works. Also, they put great care into the applications of these pieces of linen, hoping to prevent the inevitable opening of joins. I concede that it would be better to repair large openings and joins by fastening them with thin [butterfly] wedges of wood and strong glue; but this does not excuse entirely the use of linen as it is still useful in some places, although the pieces must be new and strong enough to stay in place, and they must be firmly fixed down at the ends. They may also be placed over the wedges, adding strength to strength, and plastering them down by going over them with the large soft brush [*brocha*] when applying the first layer of gesso [*yeso grueso*], and making it as level to the wood as possible. Also, all the joins on the reverse of the panels must be covered with hemp even if they have cross-bars . . . some also like to add [hemp] to the front. Others, in Castile, apply hemp over the whole panel, and, after putting on three or four layers of gesso [*yeso grueso*], they give [the panel] a thick layer of fine gesso [*yeso mate*] with a spatula. Earlier painters covered the fibrous strings with linens and applied the preparation on top, but this is [now] unnecessary, since nowadays cedar or chestnut wood is used for panels, and it is enough to apply the fibers on the reverse.<sup>8</sup>

---

## Preparation Layers

The degree to which the durability of a painting was thought to rely on the preparation is evident in a contract of 1585: “Firstly, it is a condition that the altarpiece and the tabernacle [*custodia*] are to be prepared according to the custom of the master painters in such a way that it fails not, but rather will survive in perpetuity, and otherwise [the painter] must make it again at his own expense if there should be any damage arising from fault in the preparation” (García Chico 1946:153).

The application of glue-based preparation layers to the panels was a complicated affair and one on which importance was placed not only in the contracts but also in the *ordenanzas de pintores* (civic regulations governing trade), if we are to judge by the example of the *ordenanzas* from Cordova already mentioned. Much attention to the isolation of knots and the resin they could produce is evident in contracts and even merits detailed commentary from Pacheco: “Pine is the wood ordinarily used for architecture and sculpture. It tends to weep resin, particularly from its knots, which are very large. At times, the resin even penetrates the preparation. Experience has taught that the best remedy to avoid this danger is to cover the knots with pieces of linen and very strong paste-glue [*engrudo*] after applying the glue with garlic [*gíscola*] and to make the preparation over this as it is not enough to have punctured, burned out, and gone over the knots with garlic” (Véliz 1987:86). Attempts to prevent such staining indicate that the white pine, free of knots and so prized in Castile, cannot always have been available, since painters sometimes had to deal with knots in this way.

One or several layers of parchment size or other fine glue size were applied over the wood. Contracts and guild regulations suggest that mastery was needed to achieve the successful tempering of the glue mixtures, but since both strong and weak glues are recommended in various documents, it is best to agree with Pacheco that some masters preferred a strong glue, others a weak one. He tells us, though, that whatever its strength, the glue had to be applied very hot (Véliz 1987:86–87). The first glue layer applied to the wood was frequently prepared with garlic (*gíscola*). The precise purpose of this additive is undocumented, although it is possible to hypothesize that it served not only to lower surface tension but also to act as a fungicide.

After the first glue priming, the linen or hemp cloth or fibers would be applied and then soaked with stronger glue. Although these were the most common materials, parchment (used in conjunction with hemp fibers) is named in a contract dated 1477 (Sobré 1989:53). The panel would then be ready for the preparation layers.

Gessos were formulated in Spain, as they were elsewhere, with either calcium carbonate or calcium sulphate, depending on the region; calcium carbonate was more common in Castile, calcium sulphate more common in Valencia and Andalusia (Sobré 1989:53). The most detailed account of the application of gesso layers comes from Pacheco, whose comments generally reflect local practice, although his writing is clearly informed by such sources as Cennino Cennini (author of the fifteenth-century *Il libro dell'arte*) (Cennini 1954). He tells us that “the first layer of gesso [*yeso grueso*] should be applied hot, not too thick . . . up to four or five layers (but never more than these) . . . the *yeso mate* should be applied with the same glue as the *yeso grueso* . . . I say it can be the same as the *grueso* because the thinness of the *yeso mate* moderates the strength of the glue” (Véliz 1987:66). A further warning is given when he says, “Some

think it a good idea to add a little table oil to the yeso mate, especially in winter. . . . I've also seen good gilders add linseed oil to avoid the bubbles the gesso tends to make. In my preparations I would never use either the one or the other" (Véliz 1987:66). In the contracts it is not unknown to find the number of layers of yeso grueso and yeso mate specified: "The painters must prepare all of the retablo twice with fine gesso [*guix grosso*] and twice with gesso [*guix primo*] very well tempered so that the gold will be very brilliant" (Sobré 1989:53, n. 17).

Advice also emerges from documents and treatises about the best time of year for certain preparations; adaptations for hot, cold, or dry weather also appear. In a contract from 1569 for the *retablo mayor* of Astorga, the season of the year for preparing the panels is stipulated: "And so that the said work is long lasting and permanent they must prepare [the panels] in the season that is necessary and most appropriate, which is in the eight months of winter, two before [the season of] the Nativity and two after, and the said preparation must be made with great care" (García Chico 1946:112).

Pacheco advises that the glue priming (*gíscola*) should be more strongly tempered in winter and comments that in cold places such as Castile, León and Burgos, and Valladolid and Granada, the glues are generally more strongly tempered. He adds that in wintertime the painters from these places gild with red wine in place of water and that they also sometimes add linseed oil to the yeso mate (Véliz 1987:86–87).

Most references to applying the yeso grueso and yeso mate suggest that the ground was applied in a liquid, brushable consistency and subsequently scraped and smoothed when dry. Pacheco describes a Castilian practice in which, after an application of three or four layers of yeso grueso (with a brush), thickened yeso mate is spread on with a trowel (Véliz 1987:86–87). Perhaps this use of thickened or gelled yeso mate has contributed to the notable thickness of Castilian preparation layers.

The final smoothing of the preparations of yeso grueso and yeso mate was accomplished with small, even-bladed knives (*escaretas*), which as early as 1493 were recommended in preference to *lija* (usually interpreted as sandpaper), although it is also possible that dry cuttlefish bone is meant (Ramírez de Arellano 1915:39). Pacheco also recommends a blade rather than *lija* for this purpose (Véliz 1987:88).

With increasing frequency, from the late fifteenth century through the sixteenth century, a colored priming was applied over the white yeso mate before or after the composition was drawn on the panel. A passage from Pacheco suggests that this was applied prior to drawing: "With lead white and Italian umber, make a color that is not too dark, and grind and temper it . . . with linseed oil. This is the priming. With a large brush, trimmed and soft, give the panel an even, all-over layer. After it is dry . . . it is ready to be drawn and painted upon" (Véliz 1987:67–68). Elsewhere a nearly transparent layer of gesso has been observed to "act as additional priming and to ensure that the underdrawing would not show through in the finished work" (Sobré 1989:55).

---

## Underdrawing

References to drawing on panels are rare in the documents, although there is one interesting contract that required that the master, Jaime Romeu of Zaragoza, draw all the compositions on the narrative panels and the predella, and the hands and faces of all the figures had to be painted by his

hand. The date of the contract is 1456—fairly early for such concern about authorship (Sobré 1989:38, n. 31).

Few infrared reflectograms have been published for Spanish panels, and this is an area of research that promises to be interesting. It is to be hoped that both the Prado Museum and the Instituto de Conservación y Restauración de Bienes Culturales (ICRBC) will continue the technical studies in this area that have appeared from time to time in recent years (Silva Maroto 1988:44–60; Garrido and Cabrera 1982:15–31; Cabrera and Garrido 1981:27–47). Features of Spanish underdrawings on panel include the frequent occurrence of rather bold, wide lines that seem to have been applied by brush, and the widespread use of written notations of color areas. In at least one case, an inscription that was to appear in the finished painting was recorded first in the underdrawing.<sup>9</sup> Certainly the carefully worked underdrawing associated with early Netherlandish panels is infrequent, at least in Castilian panels of the fifteenth and sixteenth centuries. This suggests a highly practical role for the drawing stage in the development of the painted image. Perhaps it also points to the use of studio pattern books that served as references for frequently repeated subjects, so that detailed drawings would not have to be worked up on the panel itself. Incised lines are occasionally evident, particularly for indicating planes in architecture or the lines radiating from a halo or dove of the Holy Spirit.

---

## Assembly of the Retable

The delicate appearance of many retables, with intricate gilt tracery surrounding images painted with the saturated tones of oil paints applied over a white ground, gives no hint of the rough construction methods often used to hold these shimmering, glowing assemblies together. This is especially the case in fourteenth- and fifteenth-century Castile, where large retables were often fitted against a preexisting apse wall. First an armature of heavy beams was secured into the wall (Fig. 7). Pieces of timber were

*Figure 7*

Fernando Gallego, *San Antonio Abad*, 1496. Oil on panel, image approx. 35 × 90 cm. San Lorenzo el Real, Toro, Zamora, Spain. The unpainted margin of a painting on panel. The holes in the gesso margin were made by large nails used to hold a piece of molding in place. The panel is part of an altarpiece that has never been dismantled.



Figure 8

An altarpiece construction typical of Castile, ca. 1500.

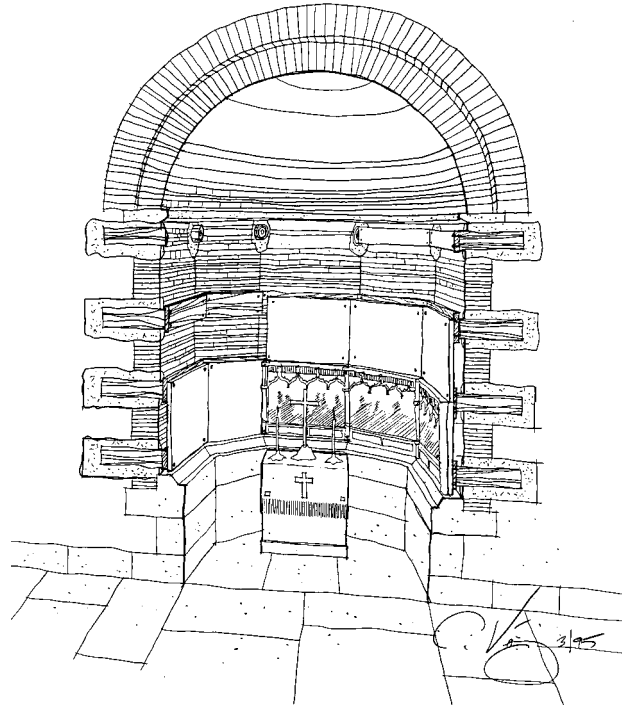

fitted at right angles some distance into the wall; holes a meter deep are not uncommon. Rubble and plaster (or adobe) were used to secure the pieces into the wall; alternatively, wooden wedges were driven between the sides of the opening and the beam to make it fast. Into these timbers, which projected 15–30 cm from the wall, upright and horizontal beams were nailed, following the contour of the wall. Most panels destined for retables were not completely covered by the painted image; usually an unpainted margin surrounded the composition (Fig. 8). The margin would eventually be concealed by tracery and served the practical function of providing an area into which the panel could be securely nailed against the timber grid. Once the panels were in place, the tracery, columns, and canopies of the altarpiece were nailed onto the front of the paintings. For most large retables of the fifteenth and early sixteenth centuries, it is unlikely that the architectural elements had any real structural role; they were applied as embellishments to panels already nailed to the armature. It is interesting to note that the use of dowels was generally restricted to the joining of panel members and crossbars or the joining of two pieces of gilt tracery. For construction, large nails, not dowels, were used freely and allowed to remain visible. It was only in the second half of the sixteenth century that countersunk nails or dowels became important, with gesso and gilding obscuring the points of contact. By the seventeenth century, the use of nails for retable construction was almost unknown, and the large Baroque structures are very skillful examples of masterful joinery and gilding. Again, the contracts reflect this change in practice: “All of which must be made with pine from Soria, well dried, and it must be very well assembled and fitted, and nothing must be stuck on or nailed, but rather, everything must be doweled and joined” (García Chico 1941:283).

Even in the late sixteenth and early seventeenth centuries, after canvas had replaced the wooden panel as the most convenient modern painting support, well-crafted pine panels were still used extensively as

backings for canvas paintings. This was a prudent measure used to “diminish the effect of our extreme climate”<sup>10</sup> on the paintings and also to render the canvases less vulnerable to damage once in place.<sup>11</sup>

---

## Acknowledgments

The author wishes to acknowledge the generous help of Juan Abelló, Caylus, Madrid; Lotta Hanson, Harari and Johns, London; Ronda Kasl, Lank-Sandén, London; Jose Navarro Talegón; Conchita Romero; Rafael Romero; and Claudio Véliz.

---

## Notes

- 1 Unless otherwise noted, all translations of these documents into English are by the present author.
- 2 Presumably, cutting the tree in a good moon (*en buena luna*) is meant to ensure that the sap has not risen, a process that renders the wood more vulnerable to microbiological deterioration. Another interesting, though less pragmatic, possibility: The sculptor Gregorio Fernández was widely held to be divinely inspired when he worked. It is recorded that before carving a statue he prepared himself with prayer, fasting, and penitence. The finished works, especially those of Christ’s Passion, were objects of exceptional reverence and extraordinary potency. Perhaps the stipulation of wood cut “en buena luna” has a ritualistic as well as a practical significance in this context. See McKim-Smith 1993:13–32.
- 3 *Ordenanzas de Granada*, sixteenth century. Biblioteca Nacional R. 31528, fol. 178. *Ordenanzas de Sevilla. Año de 1632*. Biblioteca Nacional R. 30376, fol. 162.
- 4 Although precise recipes for the material used for caulking have not been noted, it was probably a chalk putty, considerably thicker than the gessoes described elsewhere.
- 5 The most informative works known to the author are the fundamental study by Murette (1961) and, published more recently, the study by Sobré (1989). Also useful is the unpublished thesis by Prieto Prieto (1988). An admirable study of a late-sixteenth-century Castilian altarpiece provides complete technical documentation of the retablo in all its aspects (Hernández Gil 1992).
- 6 In a document of 1602 recording the sale of the contents of the studio of the painter Martín de Aguirre, it is interesting to note the value of a small amount of hemp valued at one and a half *reales*, whereas one and a half dozen brushes fetched four *reales*. In the inventory of these studio contents also appear eleven panels for painting (*once tablas de pintar*). This property was held on deposit with a sculptor for several days prior to its auction. It is curious that the eleven panels for painting did not appear at the auction. The inventory and sale documents are published. See Navarro Talegón 1984:333.
- 7 See Sobré 1989. Sobré, however, feels confident in assigning characteristic uses of fibers and cloth to regions: “In Castile, Andalusia, and sometimes in Aragon, a web of hemp fibers was glued over the back surface of each panel, except where there were bars. In Aragon and in Catalonia hemp fiber strips were commonly placed along the joining of the individual planks, rather than over the whole back. In Valencia the back was sometimes gessoed, the gesso being impregnated with hemp fibers” (p. 52).
- 8 This and all subsequent translations from Pacheco (1965) were published previously (Véliz 1987:87).
- 9 Underdrawing in the *Pietà* by Fernando Gallego in the Museo del Prado shows that Latin inaccuracies in the underdrawing note for the inscription were corrected (by a lettered friend or the client?) before being committed to paint (Cabrera and Garrido 1981:27–47).
- 10 Toledo, Convent of Santo Domingo el Antiguo. The author has seen an early-seventeenth-century contract for the carpentry and assembly of an altarpiece in which reference is made to the pine panels over which paintings were stretched as being necessary to mitigate the influence of Toledo’s harsh climate. It is also mentioned that the use of such panels is customary in Toledo. The document was not transcribed.

- 11 The paintings by El Greco for the high altar (1576) in the convent of Santo Domingo el Antiguo, as well as a large Annunciation by Eugenio Cajés (ca. 1615), in a side altar of the same convent, and the high altar by Luis Tristán (ca. 1624), in the Real Convento de Santa Clara, are all canvas paintings on their original strainer panels. The *Expolio* by El Greco in the Sacristy of Toledo Cathedral is also still mounted on its original pine panel.

---

## References

- Cabrera, J. M., and M. C. Garrido  
 1981 Dibujos subyacentes en las obras de Fernando Gallego. *Boletín del Prado* 2(4).
- Cennini, Cennino d'Andrea  
 1954 *The Craftsman's Handbook*. Trans. Daniel V. Thompson Jr. Originally published as *Il libro dell'arte*, ca. 1437. New York: Dover Publications.
- García Chico, Esteban  
 1941 *Documentos para el estudio del arte en Castilla*. Vol. 2. Seminario de arte y arqueología, Consejo Superior de Investigaciones Científicas. Valladolid: Universidad de Valladolid.
- 1946 *Documentos para el estudio del arte en Castilla*. Vol. 3. Seminario de arte y arqueología, Consejo Superior de Investigaciones Científicas. Valladolid: Universidad de Valladolid.
- Garrido, M. C., and J. M. Cabrera  
 1982 El dibujo subyacente y otros aspectos técnicos de las tablas de Sopetrán. *Boletín del Prado* 3(1).
- Hernández Gil, Dionisio, ed.  
 1992 *El retablo y la sarga de San Eutropio de El Espinar*. Madrid: Ministerio de Cultura, Dirección General de Bellas Artes y Archivos, Instituto de Conservación y Restauración de Bienes Culturales.
- Madurell Marimón, José María  
 1944 *Anales y boletín de los museos de arte de Barcelona* 2.
- 1946 El arte en la comarca alta de Urgel. *Anales y boletín de los museos de arte de Barcelona* 4.
- Marette, Jacqueline  
 1961 *Connaissance des primitifs par l'étude du bois*. Paris: Picard.
- McKim-Smith, Gridley  
 1993 Spanish polychrome sculpture and its critical misfortunes. In *Spanish Polychrome Sculpture, 1500–1800, in United States Collections*. Exhibition catalogue. New York: Spanish Institute.
- Navarro Talegón, José  
 1984 Documentos inéditos para la historia del arte, pintores zamoranos del siglo XVI. *Anuario*, Instituto de Estudios Zamoranos "Florian de Ocampo" (Zamora, Spain).
- Pacheco, Francisco  
 1965 *El arte de la pintura*. 1638. Reprint, 2 vols., ed. F. J. Sánchez Cantón, Madrid: Imprenta y Editorial Maestre.
- Prieto Prieto, Manuel  
 1988 Los antiguos soportes de madera: Fuentes de conocimiento para el restaurador. Thesis, Facultad de Bellas Artes, Universidad de Madrid.
- Ramírez de Arellano  
 1915 Ordenanzas de pintores (Córdoba). *Boletín de la Real Academia de Bellas Artes de San Fernando* 35:25–36.

- Serrano y Sanz, M.  
1914 Documentos relativos a la pintura en Aragón durante los siglos XIV y XV. *Revista de archivos, bibliotecas y museos* 31:433–58.
- Silva Maroto, María Pilar  
1988 M. P. Diego de la Cruz en el Museo del Prado. *Boletín del Prado* 9.
- Sobré, Judith  
1989 *Behind the Altar Table: The Development of the Painted Retable in Spain, 1350–1500*. Columbia, Mo.: University of Missouri Press.
- Véliz, Zahira, ed. and trans.  
1987 *Artists' Techniques in Golden Age Spain*. Cambridge: Cambridge University Press.



# Historical Overview of Panel-Making Techniques in the Northern Countries

Jørgen Wadum

**T**HROUGH MANUSCRIPTS, as well as through documentation and research in conservation studios, the methods used by old master panel makers to manufacture panels used as painting supports have become much clearer. The guild rules that have been preserved are also an important source of information to the extent that they mention points applicable to the joiners or panel makers (Miedema 1980).<sup>1</sup>

In Antwerp, the earliest documents from the guild of Saint Luke date to the last quarter of the fourteenth century, with the first regulations dated 1442 (Van Der Straelen 1855). The guild comprised not only painters but many members of the various crafts related to art production, including lace makers, instrument makers, and panel makers (Miedema 1980; Rombouts and Van Lerijs 1864–76).<sup>2</sup> Joiners were not members of the guild of Saint Luke in Antwerp, but panel makers were. Both groups made panels, but for different purposes. The sculptors had the specialized *bakmakers* (box makers) make boxes and panels for their retables; however, joiners were also allowed to make panels. When the production of altars began to slow down in the sixteenth century, the box makers began making panels on a larger scale. Thus, the box makers actually became the new generation of panel makers. During the seventeenth century, when canvas became the preferred support for paintings and the demand for panels decreased, panel making again shifted, this time to the frame makers. During the same time period, frames developed increasingly sophisticated profiles and elaborate carvings, a development that demanded a separate association of frame makers (van Thiel and de Bruijn Kops 1995). Aside from producing frames, these frame makers continued making panels for painters who preferred this rigid support.

In Germany quality control had already been introduced in the late Gothic period. In Munich the regulations of 1424 stated that four representatives from the guild of cabinetmakers were to control all panels made by fellow cabinet and panel makers (Hellweg 1924). Any irregularities were to be reported to the head of the guild, and the panel maker was to be punished accordingly.

However, as the guild rules and the relationships among the different crafts varied from town to town, a comparison is difficult (Verougstraete-Marcq and Van Schoute 1989; Dunkerton et al. 1991).

---

## Species of Wood

The artists would often use wood native to their region. Albrecht Dürer (1471–1528), for example, painted on poplar when he was in Venice and on oak when in the Netherlands and southern Germany. Leonardo da Vinci (1452–1519) used oak for his paintings in France (Nicolaus 1986); Hans Baldung (1484/5–1545) and Hans Holbein (1497/8–1543) used oak while working in southern Germany and England, respectively (Fletcher and Cholmondeley Tapper 1983). In the Middle Ages, spruce and lime were used in the Upper Rhine and often in Bavaria. Outside of the Rhineland, softwood (such as pinewood) was mainly used. A group of twenty Norwegian altar frontals from the Gothic period (1250–1350) were examined, and it was found that fourteen were made of fir, two of oak, and four of pine (Kaland 1982). Large altars made in Denmark during the fifteenth century used oak for the figures as well as for the painted wing panels (Skov and Thomsen 1982).

Lime was popular with Albrecht Altdorfer (ca. 1480–1538), Baldung Grien, Christoph Amberger (d. 1562), Dürer, and Lucas Cranach the Elder (1472–1553). Cranach often used beech wood—an unusual choice. In northern Europe, poplar is very rarely found, but walnut and chestnut are not uncommon. In the northeast and south, coniferous trees such as spruce, fir, and pine have been used (Klein 1989). Fir wood is shown to have been used in the Upper and Middle Rhine, Augsburg, Nuremberg, and Saxony. Pinewood was used mainly in Tirol and beech wood only in Sachsen.

In general, oak was the most common substrate used for panel making in the Low Countries (Peres 1988), northern Germany, and the Rhineland around Cologne.

In France, until the seventeenth century, most panels were made from oak, although a few made of walnut and poplar have been found.

The oak favored as a support by the painters of the northern school was, however, not always of local origin. In the seventeenth century about four thousand full-grown oak trees were needed to build a medium-sized merchant ship; thus, imported wood was necessary (Olechnowitz 1960). In recent years dendrochronological studies have traced the enormous exportation of oak from the Baltic region to the Hansa towns. This exportation lasted from the Middle Ages until the end of the Thirty Years War (Klein 1989). Oak coming from Königsberg (as well as Gdansk) was, therefore, often referred to as *Coninbergh tienvoethout* (10-ft., or 280 cm, planks) (Fig. 1) (Sosson 1977; Wazny 1992; Bonde 1992). The longest planks available on the market (12 ft., or 340 cm) were used by Peter Paul Rubens (1577–1640) for his *Elevation of the Cross* in the Antwerp Cathedral (Verougstraete-Marcq and Van Schoute 1989; D’Hulst et al. 1992; Verhoeff 1983).<sup>3</sup> Karel van Mander (1548–1606) was aware that oak was being imported by ship from the North Sea, although he thought it came from Norway.<sup>4</sup> The ships did come to the Netherlands from the north, after passing the Sound, the strait that now divides Denmark from Sweden, on their way from the Baltic. However, the Sound-dues records show that in 1565, 85% of the ships carrying wainscots set out from Gdansk (Wazny and Eckstein 1987).

In the last decade of the seventeenth century, Wilhelmus Beurs, a Dutch writer on painting techniques, considered oak to be the most useful wooden substrate on which to paint. Beurs reported that not all wood is favorable for panels, “and what was used by the old masters who had very durable panels, then we today can say, so much seems to be known, that we can use good oak wood” (Beurs 1692). If possible, smaller paintings

Figure 1

Vistula River basin with the main sources of wood (marked by dots). Political borders are those of the first half of the fifteenth century.

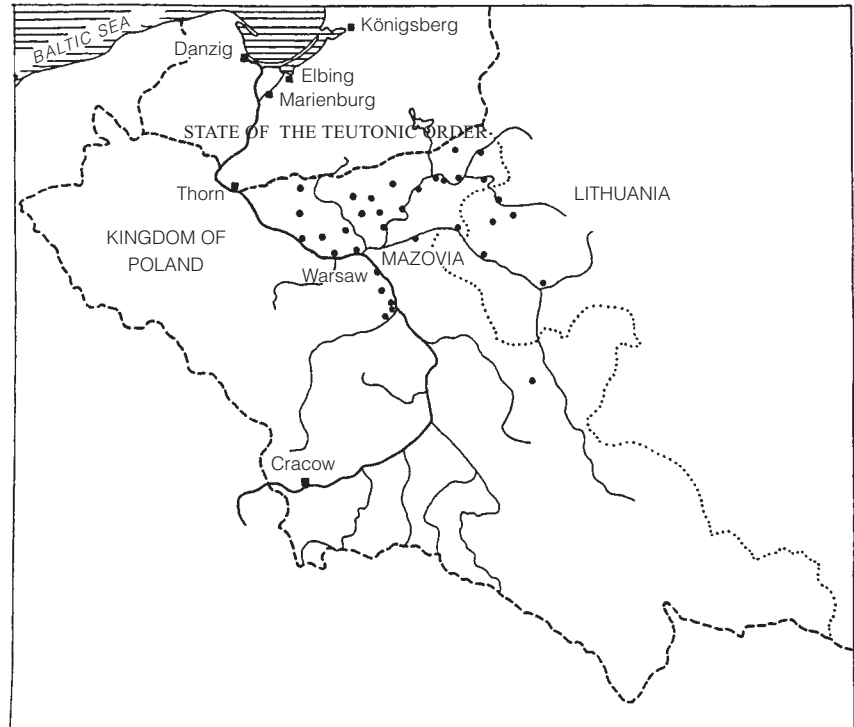

should be of only a single plank free from sapwood. The text of Beurs implicitly suggests that the use of other wood species would probably have been experimental in nature.

This recommendation for using oak is in accordance with practice. However, exceptions are seen rather early in the seventeenth century: sometimes walnut, pearwood, cedarwood, or Indian wood were used instead. Mahogany was already in use by a number of painters during the first decades of the seventeenth century and was used often in the Netherlands in the nineteenth century. Even so, when canvas or copper was not used, the main oeuvre of the northern school was painted on oak panels.

---

## Quality of Wood

The quality of an oak panel can be seen from its grain. If the medullary rays in an oak panel are visible, the quality should be good, because this shows that the plank was radially split or cut out of the tree trunk (Fig. 2). The density of the wood is also important to the quality. Before 1630–40 the year rings (whose formation depends on age, physical location, and climatological factors) are often found to be narrower than those of oak trees available after this date.<sup>5</sup>

In the sixteenth century sapwood is rarely seen on panels, but in the seventeenth century a narrow edge of it is often recognized on one side—in violation of guild rules that threatened a fine for the use of sapwood (Van Der Straelen 1855). However, as panels inspected by the guild *keurmeesters* (assay masters/inspectors) also show faults in the wood, this may well be a consequence of the higher price of wood during the politically turbulent years in the beginning of the seventeenth century; or perhaps there was such a high demand for panels that less control was exercised over their production.

*Figure 2*

Medullary rays on a radially split and cut plank. Royal Danish Collection, Rosenborg Palace, Copenhagen.

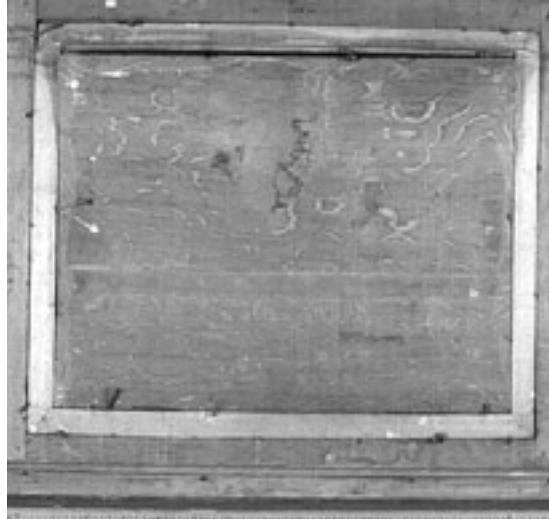

Sometimes oak shows the signs of insect attack in a light area in the middle of a plank. This light part of the wood is called a *Mondring*,<sup>6</sup> and it consists of sapwood that has not transformed itself into hardwood. This phenomenon is due to an incomplete enzymatic reaction in the wood tissue, usually caused by strong frost (Fig. 3).

---

## Tools

Splitting the timber was the usual method for obtaining radial planks of good quality, and this procedure was used by Dutch and German artisans until the sixteenth century, when the sawmill became standard for cutting large planks (Tångeberg 1986). The saw, which was known in classical times but forgotten until rediscovery in the fourteenth century, was mainly used from the fifteenth century onward. Later the wood was further treated with axes and scraping irons. The wood plane was also known to the Romans, but planing of panels did not become common until the fourteenth century (Fig. 4).

In some cases a wedge-shaped plank would be used directly; in other cases, it would be planed down. The planing would often be per-

*Figure 3*

The *Mondring*, an area of sapwood in the middle of a plank. Royal Danish Collection, Rosenborg Palace, Copenhagen.

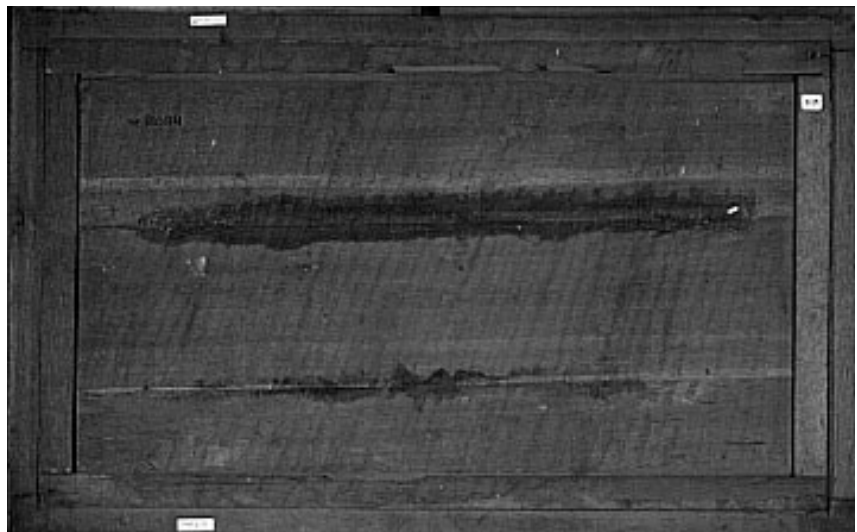

Figure 4

Gillis Mostaert, *A Landscape with Christ Healing the Blind Man*, ca. 1610. Oil on panel, 35.5 × 53 cm. Woodworkers cutting trunks with different types of saws. To the right, planks are stacked for seasoning.

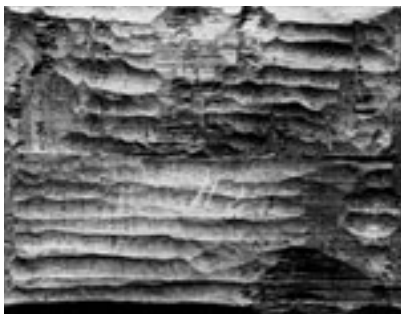

Figure 5a–d

Toolmarks on the backs of panels: (a) After joining, the panel has been partially thinned by a roughening plane. The untreated areas in the lower right and upper middle show the surface created when the wood was split into planks. (b) Three planks, all showing saw marks from a handheld saw, giving the surface a slightly (here, horizontally) wavy surface; thicker parts were planed down with a narrower roughening plane. (c) First a broad plane, with two dents in the blade clearly visible on the wood, and later a narrow plane were used to thin the planks down; remains of the saw marks are still visible in the center. (d) Three planks having been treated transversely to the grain, after having been previously treated as in Fig. 5c.

formed after the gluing of the separate planks (Fig. 5a). Plane marks crossing the joins were very common in sixteenth- and seventeenth-century planks. Tools used for this work were planes, scrapers, and, in rare instances, small axes (Marette 1961).

The toolmarks on the backs of panels constructed of multiple planks do not always reveal the same treatment. One plank, for instance, might show saw marks, where other planks on the same panel show either the use of a plane or an ax (Fig. 5b–d). The plane would often have a dent in the blade that created a ridge. These ridges have, in some instances, established that the same plane was used on different panels, which then



a

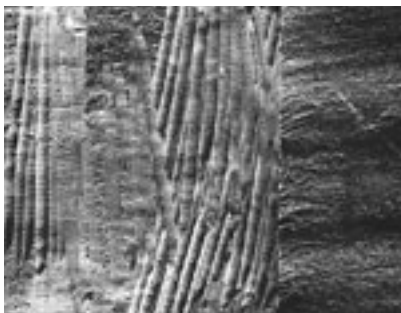

b



c

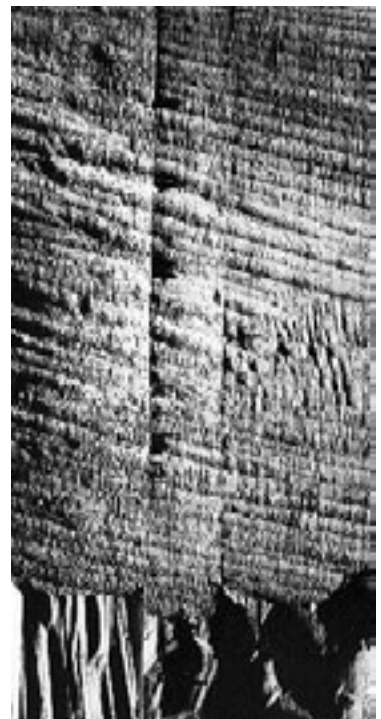

d

could be attributed to the same panel maker (Christie and Wadum 1992; Wadum 1988). Tools for carpentry dating from the seventeenth century are not particularly rare, but Skokloster Castle in Sweden houses more than two hundred planes, axes, and gouges produced in Amsterdam around 1664; they are in excellent condition (Knutsson and Kylsberg 1985).

## Panel Construction

The guild rules emphasized that the wood used in the construction of panels should be well seasoned. Seasoning the wood is very important for its stability. Wood shrinks during drying, and it may warp or show diagonal distortions if seasoning is not completed before the thinner planks are made ready for joining.

Based on dendrochronological studies, we have been able to estimate that the seasoning period in the sixteenth and seventeenth centuries was approximately two to five years, whereas it was eight to ten years in the fifteenth century (Fletcher 1984; Klein et al. 1987). The regulations of the Antwerp guild of Saint Luke were very specific about manufacture of panels for altars, wings, and smaller paintings. In 1470 a set of standards was issued stating that all altar cases and panels should be made of dry *wagenschot*<sup>7</sup> and that no painter was allowed to paint on either sculpture or panel if the wood was not dry (Van Der Straelen 1855).<sup>8</sup>

Gothic altar frontals in Norway were, on average, approximately 20 mm thick. The planks were aligned (but not glued) in the join by wooden dowels<sup>9</sup> 100–150 mm long and 10–15 mm thick. The joins of the planks were secured by parchment or canvas strips before a relatively thick (1–4 mm) ground was applied (Kaland 1982).

When more oak planks were joined together to form a large panel, planks could vary in width, although they were usually 25–29 cm wide. The panels were usually 8–30 mm thick. Panels from the fifteenth and sixteenth centuries tend to be thicker than those from the seventeenth century (Nicolaus 1986).

Planks of varying thickness were joined and then planed. In other cases, the backs were left uneven.

Traditionally, when two or more planks were glued together, heartwood was joined with heartwood, and sapwood with sapwood (Klein 1984). The planks were usually joined in such a way that the heartwood was on the outer edges.<sup>10</sup> Smaller panels consisting of two planks glued together sometimes show the remains of the lighter colored sapwood in the center of the panel (Fig. 6). This arrangement may have created problems because the remains of the weaker sapwood could cause joints to break open, and the softer sapwood would attract insects, whose infestation would be further stimulated by the animal glue used for the join.

Planks were joined in various ways (Fig. 7a–h). The majority of planks were butt-joined (Fig. 7a). Some planks would have the two edges roughened to make a better tooth to receive the animal glue (Fig. 7b).<sup>11</sup> Butterfly, or double-dovetail, keys and dowels were commonly applied for reinforcement. In the Middle Ages, the panels were glued and further reinforced with butterfly keys (Fig. 7c). If butterfly keys were used, they were placed mainly on the front of the panel, and with time they often began to show through the paint layer (Fig. 8). Butterfly keys on the backs of panels were usually later additions. As panels became thinner toward the end of the sixteenth century, dowels replaced the butterfly keys for stabilizing and aligning the joins during gluing (Fig. 7d). On X radiographs the dowels

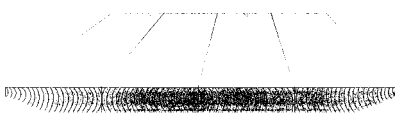

Figure 6  
The traditional method of joining planks would be like against like: sapwood against sapwood, or heartwood against heartwood.

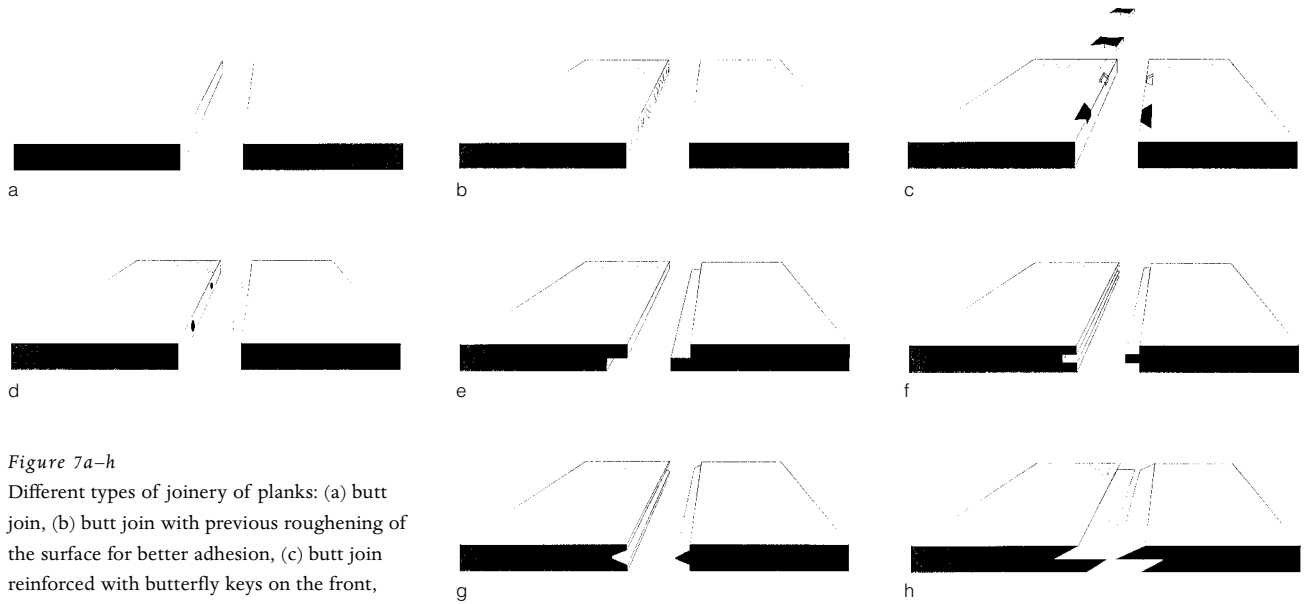

Figure 7a–h

Different types of joinery of planks: (a) butt joint, (b) butt joint with previous roughening of the surface for better adhesion, (c) butt joint reinforced with butterfly keys on the front, (d) butt joint aligned with dowels, (e) lip joint, (f) tongue-and-groove joint, (g) wedge-shaped joint, (h) Z-shaped chamfered joint (mainly used where planks with transverse grain are assembled).

and dowel holes can easily be traced, revealing the differences in method between one panel maker and another (Wadum 1987). In small panels ( $48 \times 63$  cm) consisting of two planks, two dowels would normally be placed in the joint, whereas larger panels ( $75 \times 110$  cm) made of three planks would have three dowels in each joint. Smaller panels ( $50 \times 60$  cm) made for portraits were sometimes composed of three planks—the middle one wide and the two at the edges much narrower—so that there would be no joint down the middle of the panel that might run through the subject's face.

Lip joints and tongue-and-groove joints do occur in some instances; the wedge-shaped joints are rarer (Fig. 7e–g). Additions on a panel made by Michiel Vrient for Peter Paul Rubens show a refined Z-shaped chamfered joint (Figs. 7h, 9). This type of joint was used to make a large overlap for better adhesion when the grain of the added plank ran transversely in

Figure 8

Maarten van Heemskerck, *The Resurrection of Christ*, ca. 1550. Detail. Oil on panel,  $172 \times 131$  cm. Department of Conservation, Statens Museum for Kunst, Copenhagen. Original butterfly keys on the front of a panel (see Fig. 7c) show through the paint layer.



Figure 9

Peter Paul Rubens, *Portrait of Helena Fourment*, ca. 1635. Oil on panel, 98 × 76 cm. Conservation Department, Royal Picture Gallery Mauritshuis, The Hague. A join between two planks assembled with a Z-shaped chamfered overlap (see Fig. 7h) for better interlocking of the join between planks with transverse grain.



relation to the first piece.<sup>12</sup> The panel maker was obviously aware that the joining of boards with the grain running perpendicular to each other would cause instability—something the conservation history of the panels confirms only too well.<sup>13</sup>

The south German Benedictine monk Theophilus (ca. 1100) describes the process of making panels for altars and wings (Theophilus 1979).<sup>14</sup> The individual pieces for altar and door panels are first carefully matched with the shaping tool that is also used by cask and barrel makers. The pieces are then affixed with casein. Once the joined panels are dry, Theophilus writes, they adhere together so well that they cannot be separated by dampness or heat. Afterward the panels should be smoothed with a planing tool such as a drawknife.<sup>15</sup> Panels, doors, and shields should be shaved until they are completely smooth. Then they should be covered with the hide of a horse, an ass, or a cow (Fig. 10).<sup>16</sup> On some altar frontals in Norway, several of the cracks in the wood of the panel were filled with parchment prior to application of the ground (Wichstrøm 1982).<sup>17</sup>

If the panel maker lacked hide, panels might be covered with a new medium-weight cloth, with glue made from hide and staghorns (Cennini 1971:chap. 19).<sup>18</sup>

Figure 10

Lucas Cranach the Younger, *Portrait of a Man with a Red Beard*, 1548. Reverse. Oil on panel, 64 × 48 cm. Royal Picture Gallery Mauritshuis, The Hague. Two joins reinforced with horse or cow hair.





The method of applying linen to the panels was also used by panel makers of the northern countries, as in a large (28 m<sup>2</sup>) painted fir wood lectern (1250–1300) in Torpo, Norway, in which the joins were glued and covered with canvas prior to the application of size and ground (Brønne 1982).

In Germany canvas was also applied to panels. The *Adoration of the Magi* by Stefan Lochner (active 1442–51) in the cathedral of Cologne has two wings and a main panel made of oak wood (Schultze-Senger 1988). The butt ends of the single planks (2.5 cm thick) have been glued together (Verougstraete-Marcq and Van Schoute 1989). The completed panels—on what was to become the inside of the wings and the front of the middle panel—were then completely covered with canvas. In 1568 Vasari described this method in some detail (Berger 1901:26).<sup>19</sup> A rather thick (1.5 mm or more) ground was used, which became somewhat thinner on the outside of the wings. Applying ground and paint on both sides of the wings naturally reduced movement in the wood.

The joins, knots, and resinous areas of softwood panels were continuously covered with strips of canvas. In the fifteenth century Danish cabinetmakers used the same procedure—joins and knots were covered with pieces of coarse canvas before sizing with a strong glue (Skov and Thomsen 1982).

The method of securing joins by applying parchment and gluing horse or cow hair transversely to the join, while used mainly in the fifteenth and sixteenth centuries, also continued in the first quarter of the seventeenth century (Sonnenburg and Preusser 1979). The use of canvas as a reinforcing material for panels is documented into the seventeenth century.<sup>20</sup>

The *Last Judgment* by Lucas van Leyden (1494–1533) was painted around 1526–27. The triptych consists of a center panel, with an unpainted back, and two wings, which are painted on both sides. All three panels are constructed of vertical oak planks glued flush and secured with wooden dowels placed at regular intervals (Fig. 11). The back of the center panel shows planks worked rather roughly with a curved spokeshave. The panels

Figure 11

Construction of a triptych from the first quarter of the sixteenth century. Lucas van Leyden, *The Last Judgment*, 1526–27. Oil on panel, 300.5 × 434.5 cm (open). Municipal Museum “De Lakenhal,” Leiden.

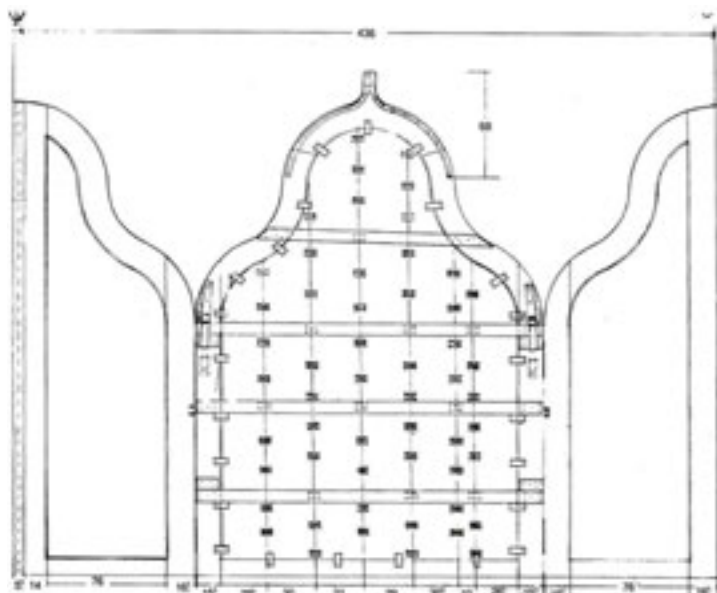

were not glued but instead were fitted into a groove in the frames. The center panel has a rabbet around the edge on the back that enhances the join with the frame. Four horizontal battens, all fastened with wooden pins, hold the center panel in place in the frame.

Although the altar was made in Leiden, it appears that the Antwerp regulations were applicable to its construction. The rule for Antwerp altars more than 2 m high required the back to be secured by transverse battens—one at the neck, with more behind the main corpus (Van Der Straelen 1855).<sup>21</sup> The whole construction would have its original greenish gray paint layer (probably original) on the back. Analysis has revealed lead white and carbon black in an oleaginous binding medium. Translucent particles (glue) were also present. It can be seen that frames and panels were all grounded in one sequence. A burr is visible along the edges of the panels, where they have been shrinking slightly (Hermesdorf et al. 1979).

Some of Rubens’s panels present a particular problem: that of enlargement with odd planks on more than one side (Sonnenburg and Preusser 1979). Sometimes the grain of these additional planks ran perpendicular to the grain of the other planks, making the composite panels especially vulnerable to fluctuating environmental conditions (Brown, Reeve, and Wyld 1982). In *The Watering Place* by Rubens, the grain of ten out of eleven planks runs horizontally. The construction of the panel took place in four successive stages, starting from a standard-sized panel of 35.9 × 56.7 cm (Fig. 12a, b). This panel was extended with additions of oak planks all having the same grain orientation, except for the final plank on the right side, which has a vertical grain. It was likely not possible to find a plank with a horizontal grain of the same height as the panels (approximately 1 m) (Brown 1996). The joins between the planks are butt

Figure 12a (right), b (opposite page)  
 Construction of the panel used by Peter Paul Rubens for *The Watering Place*, ca. 1620. Oil on panel, 99.4 x 135 cm. National Gallery, London. The sequence of added planks (a) is indicated by the numbering, and the direction of the grain is indicated by the arrows. The joins are all butt joints, except for the join of plank 10, the only plank with vertically oriented grain. Here the planks are assembled with the Z-shaped chamfered join (see Fig. 7h). The front of the painting (b) is also shown.

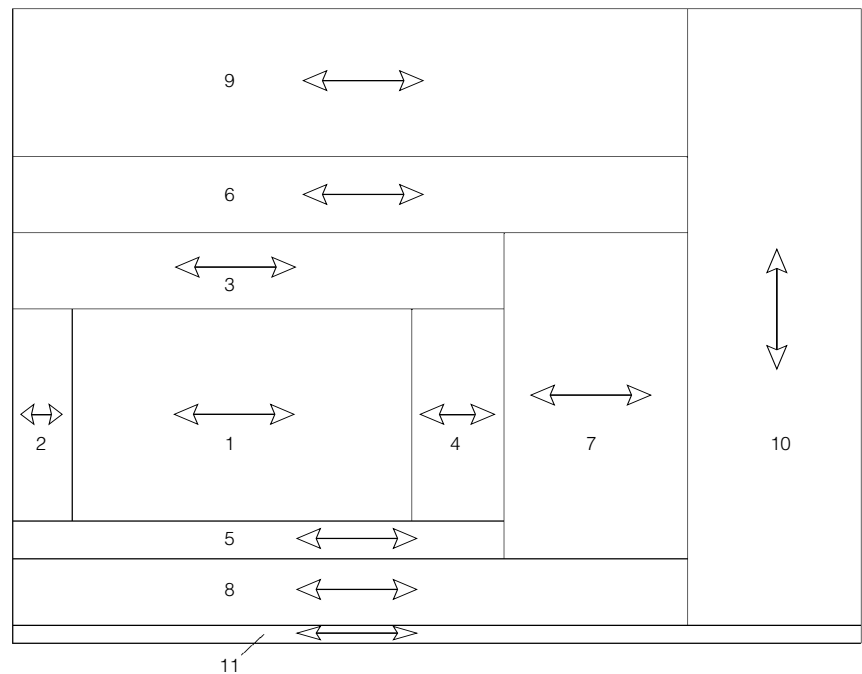

a



b

joins, except for that of the large vertical plank, which has a chamfered 3–5 cm overlap.<sup>22</sup> Such additions were often done by professionals (Rombouts and Van Lerijs 1864–76).<sup>23</sup> On X radiographs these additions appear to have been made after Rubens began his composition (Poll-Frommel, Renger, and Schmidt 1993)—toolmarks beneath the latest paint layer are observed (Sonnenburg and Preusser 1979).

In the northern Netherlands we see that Rembrandt's panels from the Leiden period are all on oak. The grain always runs parallel to the length of the panels, and joins are always butt joins (van de Wetering 1986). The panel makers in Leiden belonged to the joiners and cabinet-makers guild but are not mentioned in the guild regulations until 1627. At that time the joiners and cabinetmakers requested that the Leiden guild specify them as the producers of these panels. This request was made because a certain woodturner—not a guild member—was making and selling panels, and the joiners wanted him stopped (van de Wetering 1986).

The tradition of the Netherlandish school of the seventeenth century was applied to the French methods of the eighteenth century (Berger 1901:416). Studies of English panels show that up to about 1540, many are of crude workmanship and often have uneven joins (Fletcher 1984). However, in 1692 Marshall Smith recommended the use of old wainscot for panels because it was less likely to warp (Talley 1981).

---

## Standard Sizes

Smaller panels used for easel painting were often made in standard sizes. By the fifteenth century, altars had already been standardized (Jacobs 1989), and in the late sixteenth century, standardization was then further applied to panels made for use as painting supports (Bruijn 1979). Naturally, this standardization also became the rule for canvases (van de Wetering 1986).

The use of standard sizes for panels has been questioned (Miedema 1981); however, it has become clear that this was indeed the case for *dozijn* panels—made by the dozen (Van Damme 1990). The term has erroneously been understood by some as an evaluation of the artistic quality: it was thought that paintings on *dozijn* panels were made by mediocre painters for trade on the year markets (Floerke 1905).

The standard sizes may also have varied between towns rather than between individual panel makers.<sup>24</sup> The inventory made after the death of Frans Francken I in 1616 records nineteen *tronie*-sized (portrait) panels and forty-nine smaller, *stooter*-sized (a designation referring to a seventeenth-century coin) panels in one of his rooms (Duverger 1984). The fact that the standard sizes were also evident in the north is shown in the inventory of Jan Miense Molenaer (1610–68), which indicates that he had twenty-six single-plank panels of one size and thirty-two of a slightly larger size (van de Wetering 1986). Standard sizes are still commonly available for painters—nowadays they are called landscape, marine, or portrait sizes.

Frans Hals (1589–1666) also used standard-sized panels for many of his portraits. Hals bought panels made by members of the joiners guild in Haarlem; almost all his panels consist of a single plank (Groen and Hendriks 1989).

---

## Frames

In prints or paintings depicting a painter's atelier, frames for temporary use are often seen on the short sides (perpendicular to the grain) of a panel (Fig. 13). On panels from the fifteenth and sixteenth centuries, at the sides of the panel, one can see a small tongue that would fit into the grooves of such a temporary frame.

Panels from the fourteenth and fifteenth centuries were constructed with a fixed frame. The ground was applied at the same time to the frame and the panel, the two forming an inseparable ensemble (Dunkerton et al. 1991). If the temporary frame that was originally fixed at the short end of a panel or the full frame were removed, one would find a small beard of ground indicating the former presence of a fixed frame (Fig. 14a–d).

Frames in Antwerp were also made of beech wood—but only inner frames, in accordance with guild regulations. Additionally, for altar panels or other large works, the panel makers were *never* to use beech wood, only oak.<sup>25</sup> Original frames from the early seventeenth century are rare, but in Rosenborg Castle, Copenhagen, more than fifty are still preserved (Wadum 1988).

Beveling at the edges of a panel, often down to a few millimeters, makes it thinner and therefore easier to mount in a frame. If a panel has been reduced in size, part or all of such beveling has been removed. On small single-plank panels, however, beveling may be visible only on three sides, because when a plank is split out of a tree trunk, a wedge shape is automatically formed, so that beveling at the pointed edge is often unnecessary.

Figure 13

Maarten van Heemskerck, *Saint Luke Painting the Virgin and Child*, ca. 1550. Oil on panel, 205.5 × 143.5 cm. Musée des Beaux-Arts (inv. 307), Rennes. A narrow-grooved frame mounted at the end grain prevents the small panel from warping.



Among the hundreds of items found in the inventory made after the death of the widow of panel and frame maker Hans van Haecht (1557–1621) are thirty-six eight-*stuivers*-sized (another seventeenth-century coin) double frames in a storage room, sixty-eight more of the same size in the attic, and two dozen small ebony frames (Duverger 1987; Van Roey 1968).

Figure 14a–d

Different methods of framing: (a) a panel and frame in one piece, (b) the frame is mounted on front of the panel with dowels, (c) the panel is inserted as a tongue in the groove of the frame and is often secured by wedge-shaped blocks mounted with glue, (d) the panel is mounted in the rabbet of the frame and held with nails.

Members of the various disciplines within the guild of Saint Luke manufactured articles such as frames that would fit the standard panels (Wadum 1988; van Thiel and de Bruijn Kops 1995).<sup>26</sup> Standard frames were also constructed with a groove in which the beveled edge would fit—a method that originated with the large altar panels. The beveled edges, often varying slightly in thickness, were kept tight in the frame by means of wedges (sometimes secured by glue) placed at regular intervals on the back (Figs 14c, 15). Frames were also made with a rabbet so panels could

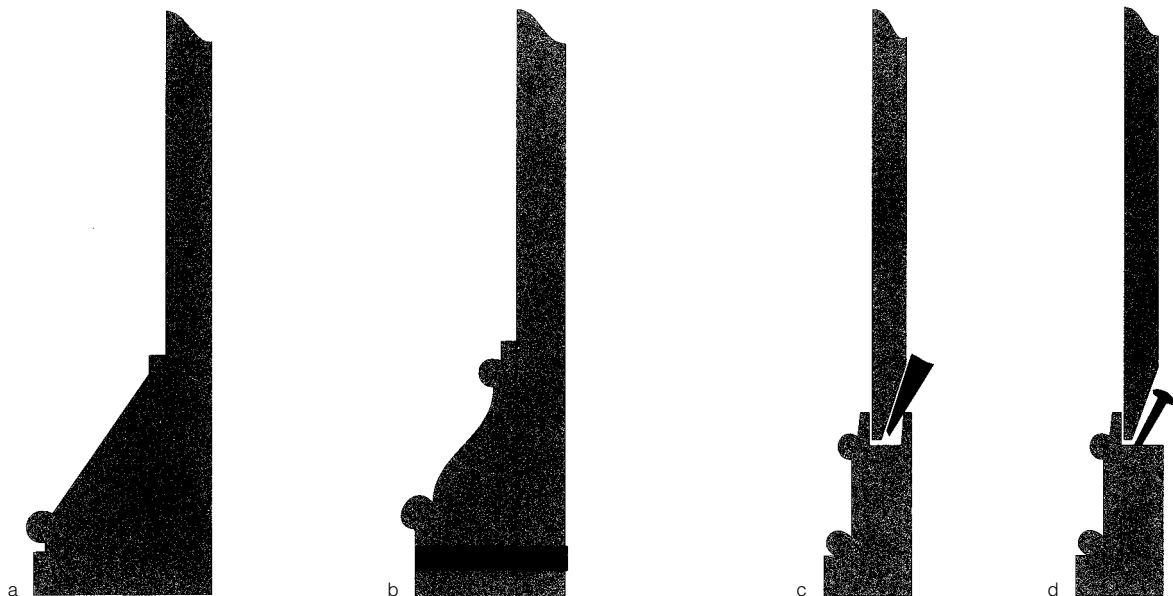

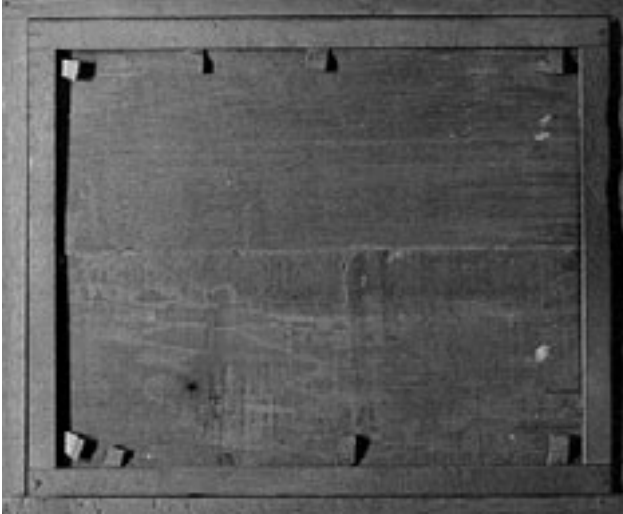

Figure 15

A panel framed in Antwerp in 1620, with the method shown in Fig. 14c. The double frame consists of a narrow beech wood frame that is itself fitted into an oak frame; the tongue-and-groove principle is followed throughout. Royal Danish Collection, Rosenborg Palace, Copenhagen.

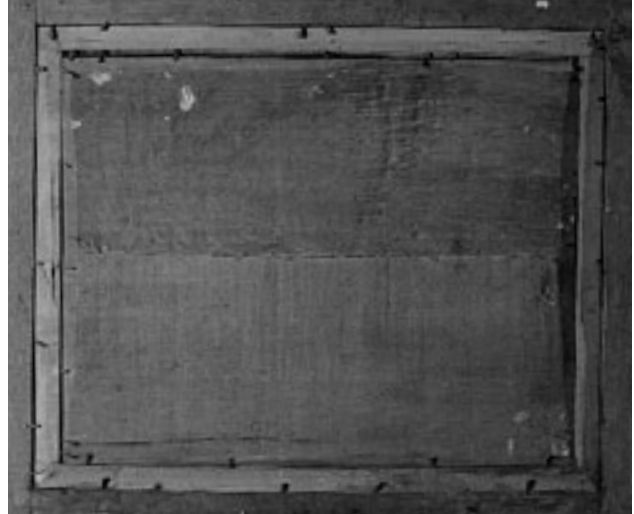

Figure 16

A panel framed in Antwerp in 1620, with the method shown in Fig. 14d. Beech wood has been used for the narrow frame; all is mounted in rabbets and held in place by hand-made iron nails. Royal Danish Collection, Rosenborg Palace, Copenhagen.

be mounted with iron nails, an easy method of framing, as the frame itself could be assembled before the panel was fitted into it (Figs. 14d, 16) (Wadum 1988; Verougstraete-Marcq and Van Schoute 1989).

## Marks

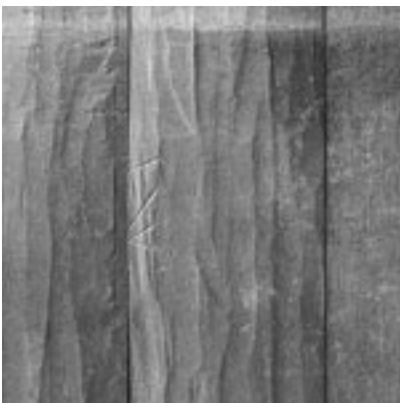

Figure 17

Maarten de Vos, *Moses Showing the Tables of Law to the Israelites*, 1574–75. Reverse. Oil on panel, 153 × 237.5 cm. Conservation Department, Royal Picture Gallery Mauritshuis, The Hague. Gouge marks made by Baltic lumberjacks can be seen.

Mainly on the back of Brabant panels, one can sometimes see lines cut with a gouge that cross one another, creating a pattern of complicated marks. It is interesting to note that these marks do not continue across joints between two planks. It has been suggested that the marks may have been made by timber tradesmen or made as a sort of quality mark for wood in stock (Marijnissen and Michalski 1960). It was also most convincingly suggested that the large planks may have been marked by the lumberjacks in the Baltic area (Glatigny 1993). The planks with such marks never have saw marks—a phenomenon showing that the planks were all split from tree trunks.

All the panels with longitudinal cut marks, found in altars or on panel paintings, seem to have been made between the end of the fifteenth century and the last quarter of the sixteenth century (Fig. 17). Most of the panels with these marks were used by painters in Brabant, Antwerp, Bruges, Brussels, or Louvain; however, a number of north German altars also have these cut marks (Tångeberg 1986). Such cut marks are to be expected on panels used in other regions in northern Europe, if the wood originated in the Baltic area where it was marked before shipment to the Hansa towns for further manufacturing.

In the early seventeenth century, when an Antwerp panel or frame maker had a large number of panels ready in his workshop, he would call for the dean, who would then pay a visit to the panel maker and check the quality of his panels (Fig. 18). If, however, the panel maker had only a few

*Figure 18*

David Ryckaert II (1586–1642), *A Painter's Atelier*. Oil on panel, 74 × 108 cm. Musée des Beaux-Arts, Dijon. The Antwerp branding mark (upside down) appears on the reverse of the small panel leaning against the back wall.

*Figure 19a–b*

The same panel back photographed in normal (a) and in UV-fluorescent (b) light. The UV-fluorescent light reveals the panel maker's check marks, the number of the panel and frame (no. 68), and the personal mark (GA in ligature), just below the join and as a fragment on the left side of the frame. The identification of the panel maker, Guiliam Aertssen, and his different inscriptions are made visible only by UV-fluorescence photography. Royal Danish Collection, Rosenborg Palace, Copenhagen.

panels he wanted to have branded, he would take them to the dean himself for approval (Van Damme 1990). This procedure was required before the panels were grounded.

If the panels had no worms, rot, or sapwood, they were accepted and branded with the hands and castle, the Antwerp coat of arms (Van Damme 1990; Wadum 1997). If, however, any faults in the wood were observed, it was the dean's duty to break the defective panel without any intervention from the panel maker or assistant (Van Damme 1990). (There are, nevertheless, numerous examples of approved panels that did have faults.) After approval and branding of the panels, the panel maker would stamp his own personal mark into the wood (Van Damme 1990). It appears that not all panel makers' marks were stamped into the wood; some were also written in red chalk directly on the board. These inscriptions are often overlooked. Yet they can be seen when the backs of panels are viewed in ultraviolet light (Fig. 19a, b) (Wadum 1990).

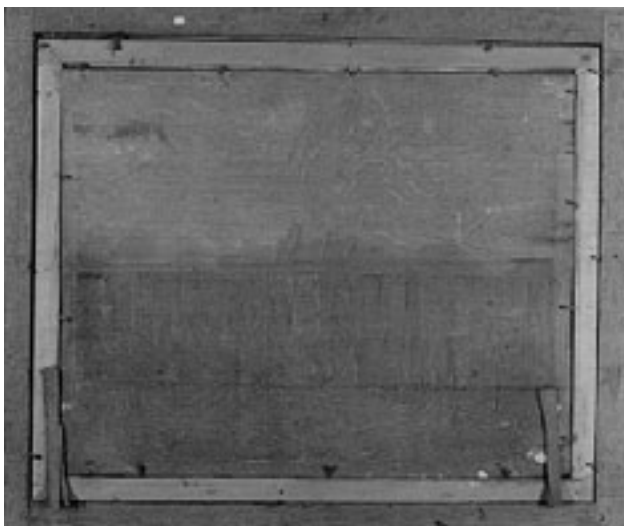

a

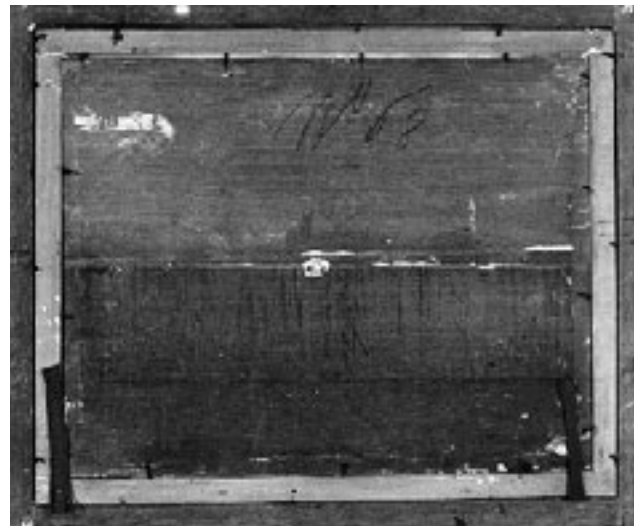

b

*Figure 20*

X radiograph of Frans Francken II, *Salome with the Head of Saint John the Baptist*, ca. 1625. Detail. Oil on panel, 50.5 × 65 cm. Department of Conservation, Statens Museum for Kunst (inv. 4457), Copenhagen. Two hands from the Antwerp branding iron show up white, as their impression is filled with a ground containing lead white.

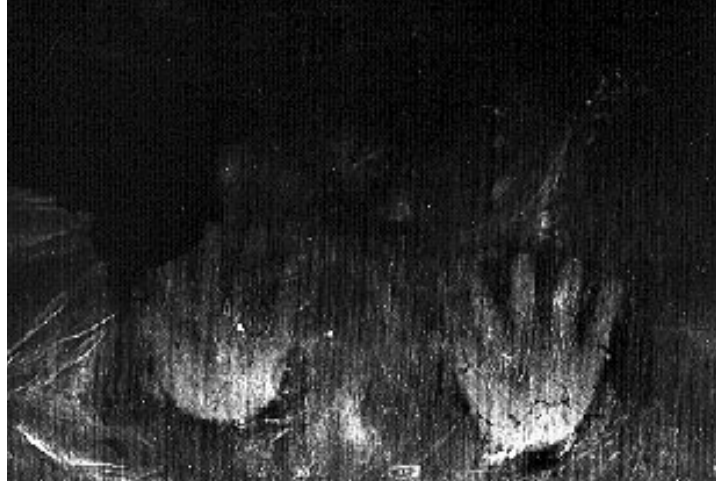

Branding of panels generally took place before the ground was applied. This can be illustrated in two particular incidents, where in both cases the ground for one reason or another was applied on the same side of the panel that had just been branded. In the first example, an X radiograph of a Rubens panel in Munich shows a white letter A, indicating that the impression of the mark had filled with ground (Sonnenburg and Preusser 1979). In a similar example, a pair of hands from the Antwerp brand shows up on an X radiograph of a panel in Copenhagen (Fig. 20).<sup>27</sup>

Panel marks existed a few years before 1617 (a panel with the maker's monogram, RB, has been found dated 1612) (Wadum 1993),<sup>28</sup> but were not standardized and regulated until a guild rule was designed to that effect the same year (Van Damme 1990). Twenty-two panel makers, as well as their respective marks, were recorded in a list.<sup>29</sup> The year 1617 has therefore in the past been regarded as the *terminus post quem* in the manufacture of panels with a maker's mark, and in general this still seems to be the case today (Figs. 21, 22). Only three other panels show the same grain and panel mark as the aforementioned panel dated to 1612, and all originate from the same large tree. The planks have been separated only by the panel maker's saw cut (Broos and Wadum 1993).<sup>30</sup> As none of the four panels show any sign of the Antwerp branding mark, one could speculate that this panel maker was a joiner, rather than a registered panel

*Figure 21, right*

The Antwerp castle, one of the two hands, and the personal mark of the panel maker, Guilliam Aertssen (GA in ligature), were partly hidden under a strip of canvas reinforcing a join.

*Figure 22, far right*

The Antwerp branding mark and the personal mark of Lambrecht Steens (LS in ligature) very thoughtfully left intact on the back of a shaved and cradled panel.







Figure 23  
Guilliam Gabron's personal mark (GG around a floral motif) pressed into the ground applied on the back of a panel, from ca. 1619. Conservation Department, Royal Picture Gallery Mauritshuis, The Hague.

## Ready-Made Grounds

maker. Joiners were not members of the guild of Saint Luke at this time and, therefore, were not monitored until 1617 by the *keurmeester* (assay master/inspector) who approved panels (Van Damme 1990).

Both the panel makers and the joiners received a new set of regulations in 1617, but the marking decree was, in fact, based on an already existing practice.<sup>31</sup> The panel maker Guilliam Gabron was already using his own mark in 1614, this mark being identical to the one we find in his early period (Fig. 23).<sup>32</sup> These exceptions only prove the rule: marking on a larger scale took place mainly after 1617.

Although ready-made panels were exported from Antwerp to other countries (Duverger 1972; Fletcher 1984), the archives mention a number of works by panel makers who were active in Holland during this period. In 1607 Evert Gerritsz of Amsterdam charged the painter Gilles van Coninxloo sixteen guilders for frames and panels. In Rotterdam in 1631 the panel and frame maker Cornelis was owed money by an art dealer, and in 1648 Dirck Willemsz received twenty-five guilders for frames delivered to an art dealer (van Thiel and de Bruijn Kops 1995).

Because panels with ready-made grounds were available in the painters' materials shops from the late sixteenth century onward, a short survey of the way the ground is described in the guild regulations, manuscripts, and painters' manuals is included here.

The application of the ground is a natural step after the panel's production; even the back of some panels may still have their original ground. This ground is generally of the same material as that used on the front, and it is often covered by a single layer of brown and/or green pigment in an oily binding medium. There are even examples of an almost black layer that is bound in thick glue. Hans van Haecht, who also operated as a dealer in paintings, had large quantities of ready-ground panels available for his customers. From an inventory we know that he had eleven gulden-sized, eighteen long eight-stuijvers-sized, and one large sixteen-stuijvers-sized panel *geprimuert* (primed) on both sides ready in his shop (Duverger 1987).<sup>33</sup>

A perusal of the panel makers' rules from the end of 1617 makes it clear that panel makers were taking over panel preparation as well. The regulations state that no panel maker may allow a panel to leave his workshop, or let it be grounded, before inspection by the dean (Van Damme 1990). Interestingly enough, the rule specifically stresses that a fine for breaking this law would be imposed, regardless of whether the offender is a man or a woman (*tsij man oft vrouwe*). Thus it is indicated that a woman, in the case of her husband's death, could take charge of a panel maker's workshop and fall subject to guild rules herself. It is also interesting to consider that women may very well have been grounding the panels produced in the workshops. This would be a fascinating piece of information regarding the division of work within the social structure of Antwerp art production, but to current knowledge, no women are titled as *witters* (grounders) in the official guild records from the seventeenth century.

It is not completely clear exactly when panel makers in Antwerp began making ready-to-paint-panels (Wadum 1993). However, when Philips de Bout (d. 1625) was registered in the *Liggeren* (the archives of the Antwerp guild of Saint Luke) in 1604, he was the first to have the title of *witter en lijstmaker* (grounder and frame maker) (Rombouts and Van Lierus

1864–76; Rooses 1878).<sup>34</sup> The availability of panels fully sized and grounded would save time and labor for an artist's atelier, so that work on a painting could start straightaway. Perhaps this is the reason why there are only three recipes in the de Mayerne manuscript (nos. 1, 2, and 4) that record how to ground panels, but many recipes (nos. 6–20) that describe how to ground canvases (Berger 1901:92–408). Canvases were also sold ready-made, although the practice was not common in this early period. On the pregrounded panel, the artist could immediately apply the imprimatura, or *primuersel*, a semitransparent colored insulation layer placed directly on the ground before painting, in whatever tone desired.

What is believed to be the mark of Philips's son Melchior (d. 1658) has been observed and recorded a number of times. In the year that he succeeded his father (1625 or 1626), Melchior de Bout is referred to as a *witter en peenelmaecker* (a grounder and panel maker); in the same year his late father is recorded only as a *witter* (Rombouts and Van Lerijs 1864–76). Panels bearing the MB monogram<sup>35</sup> have been recorded four times; the mark is placed close to a corner and pressed into a ground layer also present on the back of the panels (Fig. 24).<sup>36</sup> No Antwerp brands have been found in conjunction with this monogram. These *witters* were the initiators of this special profession of preparing panels for the artists' studios (van de Wetering 1986). In 1627 Hans van Haecht (1557–1621) had six dozen stooter-sized panels, as well as seventy-five panels of half that size, that were ready-ground with *primuur*, several on both sides (Duverger 1987).

In 1643 Leander Hendricx Volmarijn from Rotterdam got permission to sell paintings and painters' materials in a shop in Leiden. Permission was granted since no such shop existed there at that time. This fact meant that prior to this time, the painters had bought their panels directly from the joiner and panel maker (van de Wetering 1986).

In the early years, the tradition of grounding panels appears to be parallel to the method used south of the Alps.<sup>37</sup> The colored ground, or imprimatura, originated in Italy and is described by both Filarete and Vasari.<sup>38</sup> The Italian painter would make his preparatory drawings on top of the insulating, nonabsorbing, colored ground.

Figure 24

Back of a panel that has been grounded and marked by the panel maker Melchior de Bout (MB in ligature). His mark is found twice impressed into the ground on the reverse. Bonefantenmuseum, Maastricht.



Figure 25

Jan Brueghel the Elder and studio of Peter Paul Rubens, *Nymphs Filling the Horn of Plenty*, ca. 1615. Detail. Oil on panel (single plank), 67.5 × 107 cm. Conservation Department, Royal Picture Gallery Mauritshuis (inv. 234), The Hague. The streaky, transparent primuersel is seen on an infrared reflectogram.



In the north this practice changed during the sixteenth century. The underdrawing would be made directly onto the thin white ground, on top of which a translucent insulating layer, the primuersel, would be placed. This primuersel would leave the drawing visible for further development in the painting process. It is obvious, then, that the primuersel was applied in the artist's studio, not by the witter.

Karel van Mander wrote in 1605 that his predecessors ground their panels thicker than in his time and that afterward they planed or scraped the surface as smooth as they could (Miedema 1973:256–57). The technique of Hieronymus Bosch (ca. 1450–1516) is described by van Mander as a method used by many other old masters: Bosch drew his images on the white ground, placing over them a thin translucent, flesh-colored primuersel that would allow the ground to play a role in the finished painting. The fact that the old masters did indeed draw directly on the ground, using a thin, flesh-colored layer in oil as an isolation layer, has been duly confirmed by intensive studies on this subject (Federspiel 1985).<sup>39</sup> It is this pigmented oil layer that van Mander named primuersel (Fig. 25) (Plesters 1983; Coremans and Thissen 1962; Sonnenburg and Preusser 1979).<sup>40</sup>

In 1620 de Mayerne gave advice on priming a panel. If one wants to paint on wood, he wrote, it is the custom first to size with chalk. One can mix a little honey in it in order to prevent cracking; but in de Mayerne's opinion it is better not to size wood too much. Then one should apply a good and strong ground (*imprimeure*) in oil, with a knife or horn spatula, in

order to close the pores of the wood.<sup>41</sup> An English manuscript from 1622 by Peacham describes a similar method (Talley 1981:61–71).<sup>42</sup>

In 1692 Wilhelm Beurs wrote that a ground should first be applied to the panel with a weak glue mixed with chalk. After this, the panel should be scraped again in order to make it even and plane, so that the grain stays filled (van de Graaf 1958).

The same year that Beurs published his manual, the Englishman Marshall Smith gave the recommendation to apply six to eight layers of whiting mixed with a strong size. After drying, the layer should be smoothed “with a Joyners Palm, then water plain’d with a rag dipt in water” (Talley 1981:375–96). Finally, an unspecified priming is applied before a layer of colored oil imprimatur. In France in 1757, Perteny gave the advice to apply a layer of *Handschuhleim* (hide glue) on both sides of the panels, on top of which the ground should be applied (Arnold 1826:101).

The recipes are consistent with what one actually sees on sixteenth- and seventeenth-century northern European panels. In the northern Netherlands, increasingly less ground was used, so that sometimes only the holes between the more pronounced parts of the grain in the oak panels were filled. This minimal grounding caused the grain of panels painted in the seventeenth century to be partly visible through the paint film (Gifford 1983). Also, the double ground is found to have been applied to panels from the Gothic period well into the eighteenth century.

It is necessary to mention that caution must be exercised in drawing conclusions about artists’ practices from the analysis of the ground layers on paintings dating from the end of the sixteenth century onward. Indeed, the grounding—be it a single or a double ground layer and an oil, a glue, or an emulsion ground—may very well show the characteristics of what was in the pot of ground at the witter’s workshop. Therefore, no relation to the tradition of a painter’s studio may be deduced from a sample of ground. The imprimatura, or primuersel, layer was often the first layer applied by the artist on the already grounded panel; it, therefore, can be considered to reflect a specific practice in the painter’s studio.

---

## Conclusion

It becomes clear that, over the years, thick split panels for large altars evolved into smaller panels for easel painting. This shift was caused by social, religious, and economic changes. The manufacture of panels by the panel makers also underwent a development: from rough surfaces with primarily untreated backs to panels with backs that were either planed or, in some cases, protected by an isolating layer to prevent warping. The evolution of different tools, from ax to saw to plane, shows a progress in the finishing of the painter’s board that seems to decline toward the end of the seventeenth and eighteenth centuries. This development occurs along with a drop in the quality of the raw material, the wood; the presence of sapwood and broader year rings clearly tell a story about a less-consistent quality check and an apparent scarcity of dense oak.

Information garnered from treatises and manuscripts is consistent with what can be detected from the analysis of the supports, and guild rules emphasize the care and concern brought by the art-producing society to the inspection of its members. This careful oversight partly derived from a syndicalistic concept, but it is clear that its purpose was also to guarantee a purchaser works of art made of materials of high quality.

---

## Acknowledgments

The author is grateful for help and suggestions from Nicola Costaras and Feroza Verberne. A special thanks is also extended to Aleth Lorne and Victor Wadum for their support during preparation of this article.

---

## Notes

- 1 In 1581 the painters guild was founded in London; in 1595 it was founded in Prague by Rudolf II. In Leiden, however, it was founded after 1641. In Haarlem the guild of Saint Luke had been in existence since 1497 (Miedema 1980).
- 2 See Miedema (1980:94) for the structure of the guild in Haarlem; see Rombouts and Van Lierus (1864–76:699ff.) for the list of professions in the Antwerp Liggeren.
- 3 The size of the foot in selected towns in Europe in the fifteenth to the seventeenth century (one *duim* is the distance between the tip of the thumb and the first joint):
 

Riga (12 duims; 1 ell = 54.8 cm)	27.41 cm
Gdansk/Königsberg (12 duims; 1 ell = 57.4 cm)	28.69 cm
(35 Gdansk feet = 32 Rhineland feet)	
Rhineland (12 duims)	31.38 cm
Rhineland timber foot	29.43 cm
Antwerp (11 duims; 1 ell = 69.5 cm)	28.68 cm
Brussels (11 duims; 1 ell = 69.5 cm)	27.57 cm
Gent (11 Parisian duims; 1 ell = 69.8 cm)	29.77 cm
Herenthals (10 duims; 1 ell = 68.6 cm)	29.18 cm
Liège (10 duims; 1 ell = 65.6 cm)	29.47 cm
Amsterdam (11 duims; 1 ell = 68.78 cm)	28.31 cm
Copenhagen (12 duims; 1 ell = 62.8 cm)	31.38 cm
London (12 inches; 1 ell = 114 cm)	30.48 cm
Paris (12 duims; 1 ell = 111.9 cm)	32.48 cm
- 4 Here, Miedema's study, *Karel van Mander: Den grondt der edel vry schilder-const* (1973), has been used. In chapter 8, verse 3 (fol. 34v), van Mander writes, "Die ons al dienen om Landschap te stichten / Op vlas-waedt / oft Noorweeghsch 'hard' eycke plancken / Comt [which will serve us in making a landscape on either canvas or on hard Norwegian oak planks]" (see Miedema 1973:204–5).
- 5 Dendrochronological dating of the two panels in the Mauritshuis, by Dr. P. Klein in 1993, visualized this statement. On a small panel painted by Hans Memling (inv. 595), measuring 30.1 × 22.3 cm, 167 year rings were present on its narrow edge, whereas a panel approximately three times larger, measuring 62.5 × 101.1 cm, by Abraham Govaerts (inv. 45; signed and dated 1612) showed only 158 rings on its short edge. Both oak planks came from the Baltic area; the felling date, at the earliest, of the former was 1474, of the latter 1608.
- 6 The German term *Mondring*, literally "moonring" in English, does not seem to have an English equivalent when used in this context.
- 7 Long thin oak planks sawn out of the full length of the split pieces of timber.
- 8 On 9 November 1470 the rules of the guild of Saint Luke were further specified (Van Der Straelen 1855:13–14).
- 9 The dowels were inserted from the front, through the frame and into the panel. On the back, the ends of the dowels were split, and wedges were hammered into them in order to prevent movement of the dowels.
- 10 For the frontals of Norwegian altars, this was far from the case. As previously mentioned, the planks were not glued; also the back and front of the tangentially split fir wood were not oriented in the same direction. This arrangement caused an inward and outward warping of the single planks, resulting in a wavy frontal surface.
- 11 Lindberg (1990) and Skans (1990) demonstrated that ancient glues, such as those recommended by Cennino Cennini, contained from 4.5% to 8% animal fat. They state that in fifteenth-century Italy, manufacturers of glue knew the different working properties of fat and lean glues and had the capability to control the fat content of their products.

- 12 Peter Paul Rubens, *Portrait of Helena Fourment*, ca. 1635. Oil on panel, 98 × 76 cm. Royal Picture Gallery Mauritshuis (inv. 251), The Hague.
- 13 Courtesy of the archives of the Mauritshuis Conservation Department.
- 14 See chapter 17, "Panels for altars and doors; and cheese glue."
- 15 A drawknife is curved and sharp on the inside of the blade; it has two handles so that it can be drawn with both hands over the panel.
- 16 The hide was first to be soaked in water, then wrung out, and while damp laid on top of the panels with cheese glue.
- 17 It is interesting to note that the parchment (ca. before 1300) had some writing upon it. Apparently the parchment was scrap from the royal library in Bergen. The panel maker or the grounder must have been in possession of this scrap parchment for use in filling the unevenness prior to grounding.
- 18 Cennino Cennini (ca. 1437) advised his fellow Italian painters to take some canvas or white-threaded old linen cloth, soak strips of it in sizing, and spread it over the surface of the panel or ancona. See chapter 114: "Come si dè impannare in tavola [How to put a cloth on a panel]."
- 19 Vasari describes the method of applying canvas or linen to the panels before grounding and painting them. In his description, the linen not only had the advantage of covering unevenness and joints in the board but also offered a good grip for the ground (Berger 1901:26).
- 20 A premature conclusion regarding this should be avoided before thorough research has been employed, since later paintings on canvas were glued onto panels—a conservation measure already practiced by the seventeenth century.
- 21 This requirement was incorporated in a new set of rules received by the Antwerp guild of Saint Luke on 20 March 1493 (Van Der Straelen 1855:30–35).
- 22 This is comparable to the addition perpendicular to the grain on the Helena Fourment portrait in the Mauritshuis (see nn. 12, 13).
- 23 On 22 April 1626 the churchwardens of the Cathedral of Our Lady agreed that the panel set created for Rubens to paint for the high altar was too narrow. The panel maker Michiel Vrient was therefore asked to glue another plank onto the existing panel. On 11 May 1626 Vrient was paid thirty-eight guilders for enlarging the panel, and a painter named Adriaen Schut was paid to ground the panel. Drinking money was additionally given to four men who carried the panel back to the church. The artist's sole payment on 30 September 1626, however, was the gratitude of the churchwardens.
- 24 Information courtesy of chief conservator Martin Bijl, Rijksmuseum, Amsterdam, who is currently preparing an article on this topic. See also Verhoeff (1983).
- 25 These stipulations were incorporated in the regulations of 11 December 1617 for the joiners' trade (Van Damme 1990).
- 26 Also note the frame maker Reynier Roovaert (from Antwerp), who produced simple square frames or "dozen frames" ("simpel viercante lysten oft dosynwerck") and in 1637 became a master of the *kistenmakersgilde* (guild of cabinetmakers).
- 27 This information was kindly made available by conservator Mimi Bang, Statens Museum for Kunst, Copenhagen.
- 28 The panel in question is Abraham Govaerts, *Forest View with Gypsies*, 1612. Oil on panel (single plank), 62.5 × 106.2 cm. Royal Picture Gallery Mauritshuis (inv. 45), The Hague. Signed and dated: ·AGovaerts· / ·16·12·.
- 29 The most important contributions on panel makers' marks, organized chronologically by publication date, are as follows: A. Heppner (1940), G. Gepts (1954–60), H. von Sonnenburg and F. Preusser (1979), B. Cardon (1987), J. Wadum (1990), J. Van Damme (1990), M. Schuster-Gawłowska (1992), and J. Wadum (1993).

- 30 The panels in question, all of which are single planks, are (1) Jan Brueghel the Elder and studio of Peter Paul Rubens, *Nymphs Filling the Horn of Plenty* (see Fig. 25); (2) Hans Jordaens III (attrib.), *The Horatii Entering Rome*, ca. 1615, oil on panel, 67 × 110.5 cm, National-museum (inv. NM 6844), Stockholm; (3) Abraham Govaerts, *Landscape with Figures*, oil on panel, 64 × 101 cm, Kunstsammlungen der Universität, Göttingen (inv. 39), signed: A.GOVAERTS.
- 31 Meetings concerning the new regulations seem already to have taken place by the summer of 1616, when the panel makers' deans and representatives from the guild of Saint Luke met at the *Robijn* (the Ruby). An agreement was not, however, reached at this point. See Rooses 1878:73–83.
- 32 The mark of Gabron can be seen on the back of a pair of landscapes painted by Abraham Govaerts: *Woodlandscape with Huntsmen* and *Panoramic Landscape with Fishermen* (1614). Both are oil on panel, 35.5 × 51 cm. The *Panoramic Landscape* is signed: A. Govaerts 1614. Galerie De Jonckheere (cat. 7; *Œuvres de Pierre Brueghel le Jeune*, nos. 29, 30), Paris. His device of interlinking the two Gs in the monogram with a small four-leafed flower was already in use before he registered on the act of 1617, where he used only the two Gs. It bears mention that neither of the two Govaerts panels has any sign of the castle and hands of the Antwerp branding mark. Several panel makers used more than one punch during their career. The author will attempt to determine when the punches changed in a forthcoming article.
- 33 In 1757 Pertený advised applying a layer of *Handschuhleim* (hide glue) to both sides of the panels, in order to prevent swelling of the wood. As soon as the glue is dry, the side to be painted is scraped, and both sides subsequently ground, with a soft brush and a mixture of chalk and glue. Two or three layers of ground are applied. The surface of the side to be painted is evened with a damp sponge. Finally, a thin, even layer of oil paint is brushed on. Pertený refers to this layer as the isolating layer. It is stated that oil is normally mixed with lead white, a bit of "*Braunrot*" (the precise meaning of this term is not clear), and carbon black, in order to obtain a reddish gray layer. A second layer of this ground is often applied after the first one dries; this layer transforms the ground into a colored ground (an imprimatura). The last step is to smooth the final layer with a pumice or to scrape it with a knife. Panels prepared in this way, Pertený concludes, have far more value than canvases and can furthermore be used for small and detailed works.
- 34 The surname de Bout can be found in other versions: de Bont, de Baut, and Debbout. No panels with the monogram of Philips de Bout (PDB), as recorded in 1617, have been found up to the present. Other witters besides de Bout lived in Antwerp during this period: one of his neighbors in St. Antonisstrate, Adriaen van Lokeren, was also a witter, and a little farther away, in Hoplant, lived Frederick de Bout, another witter from the de Bout family. (A Frederick de Bout is mentioned in 1581 as a master violin maker) (Rombouts and Van Lerijs 1864–76).
- 35 The B is written in reverse on the inside of the right leg of the M.
- 36 The four panels are as follows: Sebastian Stoszkopf (1597–1657), *A Bowl of Fruits*, oil on panel, 26 × 34.3 cm, Galerie Leegenhoek, Paris; Wouter Gijsaerts (1649–74), *Fruits*, oil on panel, ca. 30 × 25 cm, Kunsthandel Xaver Scheidwimmer, Munich; a pair of pendants by Peeter Gysels: *A Market*, oil on panel, 40.3 × 52.2 cm, and *A Market in a Town*, oil on panel, 40.4 × 52.1 cm. On the second of the pair, the monogram of M. Bout has been pressed into the ground of the back twice. The pair of pendants is in the Bonnefantemuseum (inv. 526, 525 [RBK-NK.1790, 1863]), Maastricht.
- 37 At this stage it is useful to make a short excursion to the southern European countries in order to evaluate their method of applying the ground. Cennino Cennini (ca. 1437) (see Lindberg 1989) describes how to start work on a panel by first covering or filling holes, knots, nails, etc., with caution, so as not to smooth the surface too much. Next the panel is sized with a glue made from the clippings of sheep parchments. Two or three coats of glue are recommended; the first coat is thin in order to give the wood an "appetizer." Then the *gesso grosso* and the *gesso sottile* would be applied successively and, finally, made completely smooth (chap. 113).
- 38 Antonio Filarete (ca. 1400–1469), tells us that the colored imprimatura is applied in an opaque layer. First, the panel is made smooth, and then a layer of size is applied. Following this, a layer of paint ground in oil is applied. (The obvious color choice is lead white, but another color would also be acceptable.) Finally, the drawing is made on top (Berger 1901:6–9). Vasari (Berger

- 1901:27) says the *mestica* should first be mixed to an even color out of drying pigments such as lead white, naples yellow, or *terra da campagna*. When the ready-sized panel is dry, the mixture is applied to the entire panel surface with the palm of the hand. Vasari claims that this layer is called the *imprimatura* by many. Another earlier Italian recipe by Armenini uses this practice of mixing different pigments with a varnish or oil, in order to make a necessary color base for the other colors to be applied during the painting process. See van de Graaf (1958:22).
- 39 This extensive study is devoted to an explanation of creating a spatial illusion through the use of a *primuersel*, the thin colored isolation layer between the ground and the paint layer.
- 40 This *primuersel* is noted by some to have been applied in an aqueous medium, but no particulars of the testing methods are given.
- 41 De Mayerne does in fact state here that the grounding of wood does not have to be done exclusively with chalk and glue-water—a weak glue and a strong oil ground on top will suffice as well. However, earlier in his manuscript the contrary is stated: first, he advises the application of a ground of chalk with glue, with glue in two pots of water. When the glue is diluted, enough chalk is added to give the mixture a good consistency; the mixture is then applied smoothly and evenly with a knife. After this procedure, cerise and umber ground in oil are applied, and the panel is left to dry. Later in his manual, he recommends first priming the panel with calf- or goat-skin glue mixed with chalk. When dry, the primer should be scraped and planed with a knife and finally given a thin layer of lead white and umber. He adds that raw umber spoils the colors, suggesting instead Braunrot yellow or red ochre, lead white, and carbon black (de Mayerne, in fact, got this recipe from Abraham Latombé in Amsterdam). He later concludes that the ideal ground consists of lead white and a touch of ochre, red lead, or another color.
- 42 First the panel is planed quite evenly, and then three layers of ground (with glue) are applied. The last layer should be scraped with a knife in order to create a smooth surface, to which a final layer of colored priming, containing red lead or some other color, can be applied. After this step the underdrawing is made.

---

## References

- Arnold, H. G. C.  
1826 *Die Bereitung des Leims in ihrem ganzen Umfange*. Quedlinburg and Leipzig.
- Berger, E.  
1901 *Quellen für Maltechnik während der Renaissance und deren Folgezeit*. Munich: Callwey.
- Beurs, W.  
1692 *De groote waereld in 't klein geschildert, of schilderagtig tafereel van 's Weerelds schilderijen*. Amsterdam.
- Bonde, N.  
1992 Dendrochronology and timber trade in northern Europe from the 15th to 17th century. In *Tree Rings and Environment: Proceedings of the International Dendrochronological Symposium, Ystad, South Sweden, 3–9 September 1990*, 53–55. Lund, Sweden: Lund University.
- Brønne, J.  
1982 Torpo stavkirke—problemer omkring konserveringen av det dekorerte middelalderlektoriet med tilhørende baldakin. In *Polykrom skulptur og maleri på træ*, ed. S. Bjørnhof and V. Thomsen, 195–200. Copenhagen: Nord.
- Broos, B., and J. Wadum  
1993 Vier panelen uit één boom (Four panels from one tree). *Mauritshuis in Focus* 1:13–16.
- Brown, C.  
1996 *Making and Meaning: Rubens's Landscapes*. London: National Gallery Publications.
- Brown, C., A. Reeve, and M. Wyld  
1982 Rubens' *The Watering Place*. In *National Gallery Technical Bulletin* 6:27–39.



- Bruijn, J.**  
1979 Een onderzoek naar 17de-eeuwse schilderijformaten, voornamelijk in Noord-Nederland. *Oud Holland* 93:96–115.
- Cardon, B.**  
1987 Aantekeningen bij de Annunciatie uit het voormalige celebroedersklooster te Diest. In *Arca Lovaniensis Artes atque Historiae Reserans Documenta. Jaarboek*, vols. 15–16, ed. L. Bessemans and M. Smeyers, 29–67. Leuven: De vrienden van de Leuvense Stedelijke Musea.
- Cennini, Cennino**  
1971 *Il libro dell'arte*. Transcribed and with commentary by F. Brunello. (Original manuscript ca. 1437.) Vicenza, Italy: Neri Pozza Editore.
- Christie, N., and J. Wadum**  
1992 De grond der zinnen. *Het Mauritshuis Nieuwsbrief* 1:9–11.
- Coremans, P., and J. Thissen**  
1962 Composition et structure des couches originales. *Bulletin, Koninklijk Instituut voor het Kunstpatrimonium* 5:119.
- D'Hulst, R., F. Baudouin, W. Aerts, J. Van Den Nieuwenhuizen, M. Manderyck, N. Goetghebeur, and R. Guislain-Witterman**  
1992 *De kruisoprichting van Pieter Paul Rubens*. Brussels: Ministerie van de Vlaamse Gemeenschap.
- Dunkerton, J., S. Foister, D. Gordon, and N. Penny**  
1991 *Giotto to Dürer: Early Renaissance Painting in The National Gallery*. London: National Gallery.
- Duverger, E.**  
1972 Le commerce d'art entre la Flandre et l'Europe centrale au XVII<sup>e</sup> siècle: Notes et remarques. In *Evolution générale et développements régionaux en histoire de l'art: Actes du XXII<sup>me</sup> Congrès d'Histoire de l'Art, Budapest, 1969*, 157–81. Budapest: Akadémiai Kiadó.
- 1984 *Antwerpse kunstinventarissen uit de zeventiende eeuw*. Vol. 1 (1600–1617). Brussels: Koninklijke Academie voor Wetenschappen.
- 1987 *Antwerpse kunstinventarissen uit de zeventiende eeuw*. Vol. 2 (1618–1626). Brussels: Koninklijke Academie voor Wetenschappen.
- Federspiel, B. K.**  
1985 Observations on some technical innovations in 16th century Netherlandish painting. Thesis, School of Conservation, Copenhagen.
- Fletcher, J.**  
1984 The study of early paintings on Flemish panels. In *Jaarboek voor het Koninklijk Museum voor Schone Kunsten, Antwerpen, 1984*, 7–26. Antwerp: Royal Museum Antwerp.
- Fletcher, J., and M. Cholmondeley Tapper**  
1983 Hans Holbein the Younger at Antwerp and in England. *Apollo* 253:87–93.
- Floerke, Hans**  
1905 *Studien zur niederländischen Kunst- und Kulturgeschichte. Die Formen des Kunsthandels, das Atelier und die Sammler in den Niederlanden vom 15.–18. Jahrhundert*. Munich and Leipzig: Georg Müller.
- Gepts, G.**  
1954–60 Tafereelmaker Michiel Vriendt, leverancier van Rubens. In *Jaarboek voor het Koninklijk Museum voor Schone Kunsten, Antwerpen, 1954–60*, 83–87. Antwerp: Royal Museum Antwerp.

- Gifford, E. M.  
1983 A technical investigation of some Dutch seventeenth-century tonal landscapes. In *Preprints of the 11th Annual Meeting: American Institute for Conservation, Baltimore, 25–29 May 1983*, 39–49. Washington, D.C.: AIC.
- Glatigny, Jean-Albert  
1993 Des marques énigmatiques. In *Antwerpse retables 15de–16de eeuw*, vol. 2, 142–43. Antwerp: Museum voor Religieuze Kunst.
- Groen, K., and E. Hendriks  
1989 Frans Hals: Een technisch onderzoek. In *Frans Hals*, 109–27. Exhibition catalogue. The Hague: SDU.
- Hellweg, F.  
1924 *Die Geschichte des Deutschen Tischler-Handwerks*. Berlin: n.p.
- Heppner, A.  
1940 Ingebrande Merkteeeken ("Brandmerken") en hun waarde voor de kennis van schilderijen. *Oud Holland* 57:172–80.
- Hermesdorf, P. F. J. M., M. L. Wurfain, K. Groen, J. R. J. van Asperen de Boer, and J. P. Filedt Kok  
1979 The examination and restoration of *The Last Judgement*. In *Lucas van Leyden: Studies*, 311–424. Nederlands Kunsthistorisch Jaarboek, vol. 29. Haarlem: Fibula-Van Dishoeck.
- Jacobs, L. F.  
1989 The marketing and standardization of south Netherlandish carved altarpieces: Limits on the role of the patron. *Art Bulletin* 71(2):208–29.
- Kaland, B.  
1982 Antemensalene ved Historisk museum i Bergen. In *Polykrom skulptur og maleri på træ*, vol. 2, ed. S. Bjarnhof and V. Thomsen, 167–77. Copenhagen: Nord.
- Klein, P.  
1984 Dendrochronological studies on panels by Jean Fouquet (1415/20–1477/81). In *ICOM Committee for Conservation 7th Triennial Meeting, Copenhagen, 10–14 September 1984, Preprints*, ed. Diana de Froment, 84.1.25–26. Paris: ICOM Committee for Conservation.  
1989 Zum Forschungsstand der Dendrochronologie europäischer Tafelmalerei. *Restauratorenblätter: Holztechnologie und Holzkonservierung, Möbel und Ausstattungen* 10:35–47.
- Klein, P., D. Eckstein, T. Wazny, and J. Bauch  
1987 New findings for the dendrochronological dating of panel paintings of the fifteenth- to seventeenth-century. In *ICOM Committee for Conservation 8th Triennial Meeting, Sydney, Australia, 6–11 September 1987, Preprints*, vol. 1, ed. K. Grimstad, 51–54. Marina del Rey, Calif.: Getty Conservation Institute.
- Knutsson, J., and B. Kylsberg  
1985 *Verktyg och verkstäder på Skoklosters slott: Skokloster-studier nr. 19*. Exhibition catalogue. Bålsta, Sweden: Skoklosters slott.
- Lindberg, B. O.  
1989 Cennino Cennini, den okände målaren. In *Målningens anatomi: Material, teknologi, bevaring, förfalskning*, 39–48. Lund: n.p.  
1990 Feta och magra limmer enligt Cennino Cennini (Fat and lean glues according to Cennino Cennini). *Meddelelser om Konservering* 4:165–92.
- Marette, J.  
1961 *Connaissance des primitifs par l'étude du bois*. Paris: Picard.

- Marijnissen, R., and M. Sawko Michalski  
1960 De twee gotische retabels van Geel: Een onderzoek van materiële feiten. *Bulletin van het Koninklijk Instituut voor het Kunstpatrimonium, Brussels* 3:143–62.
- Miedema, H.  
1973 *Karel van Mander: Den grondt der edel vry schilder-const (1604)*. Utrecht: Haentjens Dekker & Gumbert.
- 1980 *De archiefbescheiden van het St. Lukasgilde te Haarlem 1497–1798*. Alpen aan den Rijn, Netherlands: Canaletto.
- 1981 Verder onderzoek naar zeventiende-eeuwse schilderijformaten in Noord-Nederland. *Oud Holland* 95(1):31–49.
- Nicolaus, K.  
1986 *DuMont's Handbuch der Gemäldekunde: Material-Technik-Pflege*. Cologne: DuMont.
- Olechnowitz, K. F.  
1960 *Der Schiffbau der Hansischen Spätzeit. Eine Untersuchung zur Sozial- und Wirtschaftsgeschichte der Hanse*. Weimar: Hermann Boehlay.
- Peres, C.  
1988 Materialkunde: Wirtschaftliche und soziale Aspekte zur Gemäldeherstellung in den Niederlanden im 17. Jahrhundert. *Zeitschrift für Kunsttechnologie und Konservierung* 2:263–96.
- Plesters, J.  
1983 *Samson and Delilah: Rubens and the art and craft of painting on panel*. *National Gallery Technical Bulletin* 7:30–50.
- Poll-Frommel, V., K. Renger, and J. Schmidt  
1993 Untersuchungen an Rubens-Bildern—Die Anstückungen der Holztafeln. In *Bayerische Staatsgemäldesammlungen. Jahresbericht*, 24–35.
- Rombouts, P., and T. Van Lerijs  
1864–76 *De Liggeren en andere Historische Archiven der Antwerpse Sint-Lucasgilde*. Antwerp and The Hague: Baggerman.
- Rooses, M.  
1878 *Boek gehouden door Jan Moretus II, als deken der St. Lukasgilde (1616–1617)*. Antwerp: Kockx.
- Schultze-Senger, C.  
1988 Der "Altar der Stadtpatrone" in der Hohen Domkirche zu Köln. *Zeitschrift für Kunsttechnologie und Konservierung* 1:87–95.
- Schuster-Gawłowska, M.  
1992 *Znaki cechowe na odwrociach flamandzkich obrazów na drewnie: Propozycja systematyki i dokumentacji (Guild Marks on the Backs of Flemish Panel Paintings: An Attempt at Systematization and Documentation)*. Krakow: Akademia Sztuk Pięknych w Krakowie.
- Skans, B.  
1990 Tillverkning och analys av gamla limmer (Manufacturing and analysing ancient animal glues). *Meddelelser om Konservering* 4:145–64.
- Skov, E., and V. Thomsen  
1982 Bernt Notkes altertavle i Aarhus domkirke: Nye undersøgelser. In *Polykrom skulptur og maleri på træ*, ed. S. Bjarnhof and V. Thomsen, vol. 2, 142–62. Copenhagen: Nord.
- Sonnenburg, H. von, and F. Preusser  
1979 Rubens: Gesammelte Aufsätze zur Technik. *Mitteilungen* 3.

- Sosson, J. P.  
1977 *Les travaux publics de la ville de Bruges, XIVe et XVe siècles: Les matériaux, les hommes.* Brussels: n.p.
- Talley, M. K.  
1981 *Portrait Painting in England: Studies in the Technical Literature before 1700.* London: Paul Mellon Centre for Studies in British Art.
- Tångeberg, P.  
1986 *Mittelalterliche Holzskulpturen und Altarschreine in Schweden.* Stockholm: Kungl. Vitterhets Historie och Antikvitets Akademien.
- Theophilus  
1979 *On Divers Arts.* Trans. J. G. Hawthorne and C. S. Smith. Ca. 1100. Reprint, New York: Dover.
- Van Damme, J.  
1990 De Antwerpse tefereelmakers en hun merken: Identificatie en betekenis. In *Jaarboek voor het Koninklijk Museum voor Schone Kunsten, Antwerpen, 1990*, 193–236. Antwerp: Royal Museum Antwerp.
- van de Graaf, J. A.  
1958 *Het De Mayerne Manuscript als bron voor de schilderkunst van de barok.* Mijdrecht, Netherlands: Verwey.
- van de Wetering, E.  
1986 *Studies in the workshop practice of the early Rembrandt.* Diss., Amsterdam.
- Van Der Straelen, J.  
1855 *Jaarboek der vermaerde en konstrijke gilde van Sint Lucas binnen de stad Antwerpen.* Antwerp: P. Th. Moons Van Der Straelen.
- Van Roey, J.  
1968 Het antwerpse geslacht Van Haecht (Verhaecht): Tafereelmakers, schilders, kunsthandelaars. *Miscellanea Jozef Duverger*, vol. 1, 216–30. Gent, Belgium: Vereniging voor de geschiedenis der textielkunsten.
- van Thiel, P. J. J., and C. J. de Bruijn Kops  
1995 *Framing in the Golden Age; Picture and Frame in 17th-Century Holland.* Zwolle, Netherlands: Waanders.
- Verhoeff, J. M.  
1983 *De oude Nederlandse maten en gewichten.* Amsterdam: P. J. Meertens-Instituut.
- Verougstraete-Marcq, H., and R. Van Schoute  
1989 *Cadres et supports dans la peinture flamande aux 15e et 16e siècles.* Heure-le-Romain, Belgium: H. Verougstraete-Marcq.
- Wadum, J.  
1987 Vinterstuen på Rosenborg Slot. Tilblivelse og datering af 75 tavlemalerier & selve gemakket. Thesis, School of Conservation, Copenhagen.  
1988 The winter room at Rosenborg Castle: A unique survival of Antwerp mass-production. *Apollo* 318:82–87.  
1990 Seventeenth-century Flemish panel makers' red chalk master marks. In *ICOM Committee for Conservation 9th Triennial Meeting, Dresden, German Democratic Republic, 26–31 August 1990, Preprints*, vol. 2, ed. K. Grimstad, 663–66. Los Angeles: ICOM Committee for Conservation.

- 1993 Recent discoveries on Antwerp panel makers' marks. *Technologia Artis* 3:96–100.
- 1997 The Antwerp brand on panel paintings. In *Leids Kunsthistorisch Jaarboek 1997*. Baarn, Netherlands: De Prom.
- Wazny, T.**
- 1992 Historical timber trade and its implications on dendrochronological dating. In *Tree Rings and Environment: Proceedings from the International Dendrochronological Symposium, Ystad, South Sweden, 3–9 September 1990*, 331–33. Lund, Sweden: Lund University.
- Wazny, T., and D. Eckstein**
- 1987 Der Holzhandel von Danzig/Gdansk—Geschichte, Umfang und Reichweite. *Holz Roh-und Werkstoff* 45:509–13.
- Wichstrøm, A.**
- 1982 De norske antemensaler, Problemer i forbindelse med tids- og stedbestemmelse. In *Polykrom skulptur og maleri på træ*, ed. S. Bjarnhof and V. Thomsen, vol. 2, 163–66. Copenhagen: Nord.

# The Making of Panels

## History of Relevant Woodworking Tools and Techniques

*Philip Walker*

**W**OOD HAS AN EXTRAORDINARY COMBINATION of properties that enable it to be used—even to be the material of choice—for thousands of different purposes, including the constitution of panels on which to paint. However, it presents the would-be user with a few minor problems, one of which is that nature delivers it to us in the round, whereas most of its uses require a flat surface. Hence, one of the tasks that woodworkers have faced throughout the ages is the conversion of round trunks or logs into flat beams or boards with square edges. This has been achieved by cleaving (Fig. 1), hewing (Fig. 2), sawing (Fig. 3), or a combination of these techniques.

Cleaving, which may be the oldest method, can be done with simple wedges, nowadays usually made of metal, even though wooden ones can be just as effective; with handled wedges, which look like axes but have important differences in their construction; or with a long, knifelike tool called a froe or riving knife (Fig. 4). It is distinctly possible, at least for the smaller and more modest paintings, that panels were produced by a cleaving or riving process similar to that still used for making roof shingles (Fig. 5).

*Figure 1*

Monks cleaving tree trunks, ca. 1100. It is likely that this rather knotty log is being split for firewood; nevertheless, the same technique was used to get boards for woodworking purposes. With a series of wedges, often themselves made of wood, flat slabs can be produced that require only a little work with an adze or a plane to true and smooth them. Note that the tool held by the smaller monk is a handled wedge, not an ax; most axes would soon be ruined by pounding, even with a wooden maul, and in any case they were too slim to act as effective wedges. S. Gregorius Magnus, *Moralia in Job*, part 2, Cîteaux, twelfth century. Manuscript illumination. Bibliothèque Municipale de Dijon, Dijon, France.



*Figure 2*

Hewing a tree trunk into a balk. There are many medieval representations of this process, some of which show that the artist was confused about the practical details. This example, with the tree supported on trestles and each man working the timber to his left, his right hand and his right leg forward, is entirely feasible, although there are refinements of the technique that had certainly been practiced in Roman times. Carpenters' window, Chartres Cathedral, ca. 1250. Stained glass.

*Figure 3*

Ripsawing a balk into planks using a two-man framed saw. The balk is supported at an angle on a single pair of crutches in a procedure that has become known as the seesawing method. *Noah Directing Sawing for the Ark*, thirteenth century. Fresco. Basilica San Francesco, Assisi.

*Figure 4*

Two froes. The froe is a riving tool that is started into the end grain of a piece of timber with a blow from a wooden club. The split that has thus been started is then extended and controlled by up-and-down leverage on the handle.

Hewing is done with axes. Like cleaving, it appears to have been practiced, in a crude way, from the very earliest period of humankind's use of tools. By the later Middle Ages, it had become a sophisticated technique involving specialized axes (Fig. 6), which was fast and accurate as well as economical, in that much of the waste could be used productively. It is unlikely that panel material was ever produced by hewing alone. Beams were habitually taken straight from the ax, but when thin panel stuff was required, it would normally have been sawn from a hewn balk, a procedure that took advantage of the flat surfaces and right-angled edges produced by the preliminary hewing. Nevertheless, the hewing ax (or side ax, as it is often called, by virtue of its edge being beveled on one side only) was a tool of preference in all stages of woodworking up to the final

*Figure 5*

Thin slabs of wood being split off by the use of a froe. Today the method is best known as a way of making roof shingles, but there is clear evidence of its having been used for the production of panels in the Middle Ages.



finishing, as can be seen in illustrations of seventeenth- and eighteenth-century workshops (Fig. 7a, b).

Sawing, although depending on a tool that is modern in comparison with the wedge and the ax, has quite a long history, as ancient Egyptian and Etruscan evidence shows (Fig. 8). Until some three hundred years ago, the limitations of metallurgy and of metalworking techniques meant that an open saw blade could not be pushed without its buckling. But this was not a serious drawback as the saw could either be pulled, as it still is in some Asian countries, or be held under tension in a wooden frame, still the preferred solution in many continental European countries. In either case, quite astonishing accuracy was obtainable by specialist sawyers (Fig. 9). J. A. Roubo, in *L'art du menuisier*, published in 1769, warns his readers that even though it is possible to saw eleven sheets of veneer out of one inch of timber, in his opinion, eight to the inch gives the minimum thickness to allow proper finishing after the veneer has been laid

*Figure 6*

Some of the types of broad ax used for shaping timber in medieval Europe. Most have edges beveled on one side only, like chisels, and are therefore designed for either right-handed or left-handed use.







a



b

Figure 7a, b

Workshops belonging to joiners who appear to have specialized in supplying artists' needs such as frames, boxes for paints, palettes, easels, and panels. Note the prominence of ax usage even in such workshops engaged in light and delicate work. (a) Jan Joris van Vliet (associated with Rembrandt), 1635, etching; (b) decoration of a delftware plate, 1769.

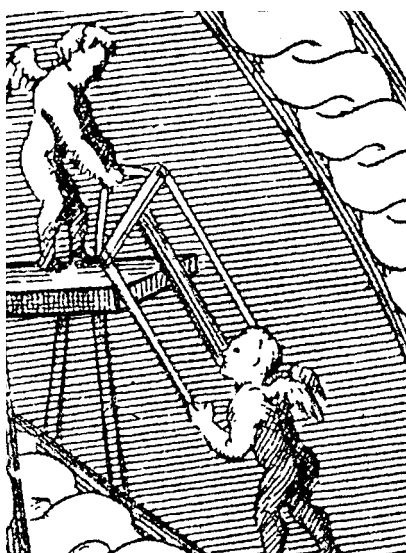

Figure 8, above

Line rendering of painting on an Etruscan bowl (ca. 500 B.C.E.), which demonstrates the antiquity of sawing as a method of converting timber. Here the two-putto saw is cutting a thick plank held horizontally on high trestles. Saws like this, held under tension in wooden frames, could have long, thin blades and could be pushed or pulled. Open-bladed saws, which had been used in Egypt for similar purposes since at least 2000 B.C.E., could not be pushed without buckling.

(Roubo 1769). Admittedly the French inch was then 27 mm—about one-sixteenth greater than today's inch—but even so, taking into account the loss in sawdust, the skill that would have been required is almost beyond imagination.

With such accurately sawed timber available, artisans could proceed directly to the next stage in preparing a panel, but cleft or hewn surfaces might well require some preliminary trueing and flattening, normally done with an adze (Fig. 10). Here again, the accuracy achieved by skilled



Figure 9

Sawyers producing veneers (Roubo 1769:pl. 278).

Figure 10, right

A group of adzes. Used with a chopping action toward the user and usually cutting across the grain, adzes were the tools of preference for smoothing or hollowing wood. The long-handled example is still fairly familiar in wooden boatbuilding and certain other trades, but the shorter ones, known as stirrup or slot adzes, were likely to have been the panel maker's choice. Ancient Egyptian adzes have been dated to 1450 B.C.E.



Figure 11, far right

Workman, using a stirrup adze, works across the grain of a board that he is holding in his hand. Detail of Lasinio's nineteenth-century engraving (from his *Pitture a fresco del Camposanto di Pisa* [Florence, 1812, 3/1828]) of Piero di Puccio's 1390 fresco *Noah's Ark*, in the Camposanto, Pisa.



workers is such that the surface may appear to the modern eye to have been planed (Fig. 11).

Once reasonably true and flat surfaces have been produced, the next step is to obtain sufficient width for the desired panel. Here we come up against the second problem that nature presents.

More than half the total weight of a newly felled tree may be water. As the wood dries out to the point at which it reaches stability with the ambient humidity, it will shrink in its width and is liable to crack or warp, depending on how it has been cut. The only boards reasonably free from these tendencies are ones radiating directly from the tree's heart (Fig. 12a–c). Since the heart itself is pith and must be discarded, the widest quartered (that is, radial) board will be somewhat less than half the diameter of the tree. Various methods have been used to get the maximum number of such quartered boards from any given log, all involving a certain inevitable wastage. But one might imagine that through most of history, merchants were content to take the four radial, or eight virtually radial, boards that presented themselves when the log was first opened into quarters, sell those at a high price, and saw up the remainder as less valuable material.

If a panel of greater width than one quartered board is required, and if a heavy and willful wood such as oak is being used, it will be necessary to join two or more boards edge to edge. As N. E. Muller has pointed out, an alternative that seems to have been preferred in fourteenth-century Italy was to use a milder, lighter wood such as poplar; take a full-width board produced by the simple method of "plain," or "through-and-through," sawing; and then restrain its tendency to distort by fixing it to a substantial framework or battening (Muller 1993).

If boards are to be joined edge to edge, they must be made to fit closely. This almost inevitably requires the use of a long, finely adjusted plane, although the ancient Egyptians, who did a lot of painting on their elaborately assembled and jointed wooden coffins and mummy cases, did not possess planes. They probably managed by the tedious process of rub-

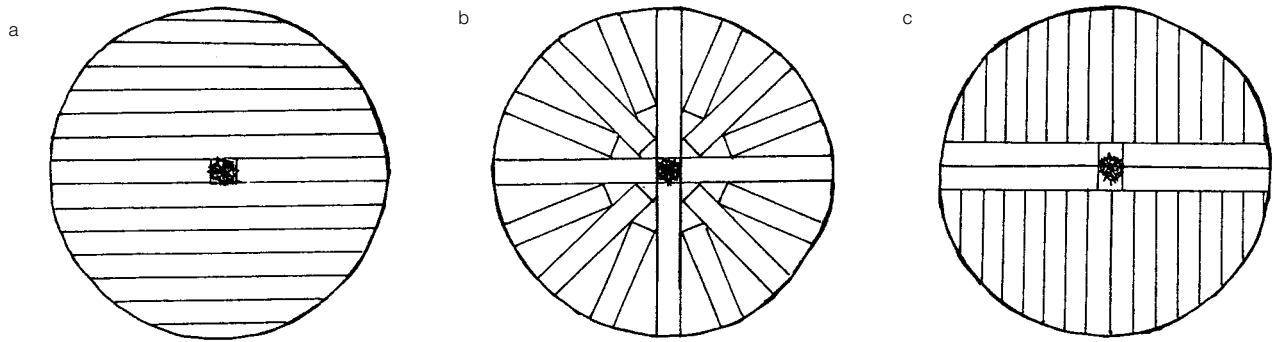

Figure 12a–c

Three ways of sawing a tree into boards: (a) the simplest method, producing only two truly radial boards; (b) another method yields all radial boards, but the pattern is difficult to saw, and it leaves a lot of waste; and (c) a simple method that yields eight virtually radial boards.

Figure 13

Illustration from Agostino Gallo's *Tredici Giornate* (published in Venice in 1566 by Bevilacqua), showing three types of plane that perform the three basic functions of the woodworking plane, regardless of the great variety of external appearances and names favored in different countries at different times. These functions are (1) getting rid of waste as fast as possible in order to produce a workpiece of roughly the desired dimensions. The plane in the center fills this role and would today be called a jack or roughing plane; (2) producing geometrically accurate faces on workpieces, usually so that they will form a perfect fit with other pieces, as in the case of the multisection panels under discussion. The length and truth of the plane's sole (underside) are the essential features, as a straight plane pushed over an uneven face will go on cutting off high points until the surface is as true as the plane itself. Such planes, of which that at the bottom is an example, are called try planes because they true (or "try") the workpiece; and (3) smoothing the visible surface of a finished artifact so that it is agreeable to touch and sight. For this purpose the plane's cutter must be finely set in a narrow mouth in the plane's sole, and smoothing planes should be short, as geometric accuracy is no longer important, and the plane can be allowed to ride the ups and downs of major undulations without having to level them. The top two planes fit this requirement.

bing adjoining parts together with sand as an abrasive. Roman planes—the earliest known examples of this valuable woodworking tool—have been found up to 44 cm in length. This is rather shorter than the modern joiner's try plane, but considerably longer ones are evident from the later Middle Ages (Fig. 13).

The preferred method of producing an accurate edge joint with a long plane is to lay out all the pieces side by side in the order in which they are to be assembled, identifying the top, or face, side with a mark across all the pieces (Fig. 14) and then "folding" each adjoining pair in turn, putting them back to back into a vice or other holding device. Shooting with the long plane along the two edges thus held closely together will produce two surfaces that are straight along their length. Any inaccuracy in their width caused by the plane's having been tilted to one side or the other will automatically be compensated for when the two pieces are "unfolded" back into a single surface.

A closely matching fit between each pair of boards having thus been achieved, the joint must be fixed. In the case of panels for painting,

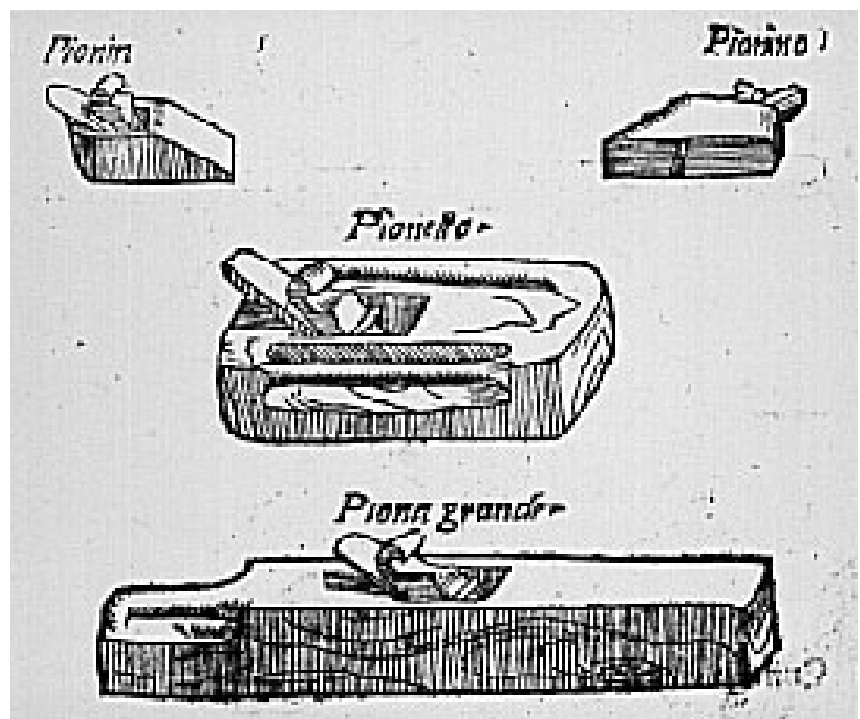

Figure 14

Roubo's illustration for the making up of panels (Roubo 1769:pt. 1, pl. 18). At the bottom, four boards are marked so that they will be kept in the intended order and relative position when they are trued and glued. There are clamping devices to hold them together while the glue is setting, glue pots and brushes, and, at the top, tonguing and grooving planes with their cutters, in case it is desired to joint the board edges in this way.

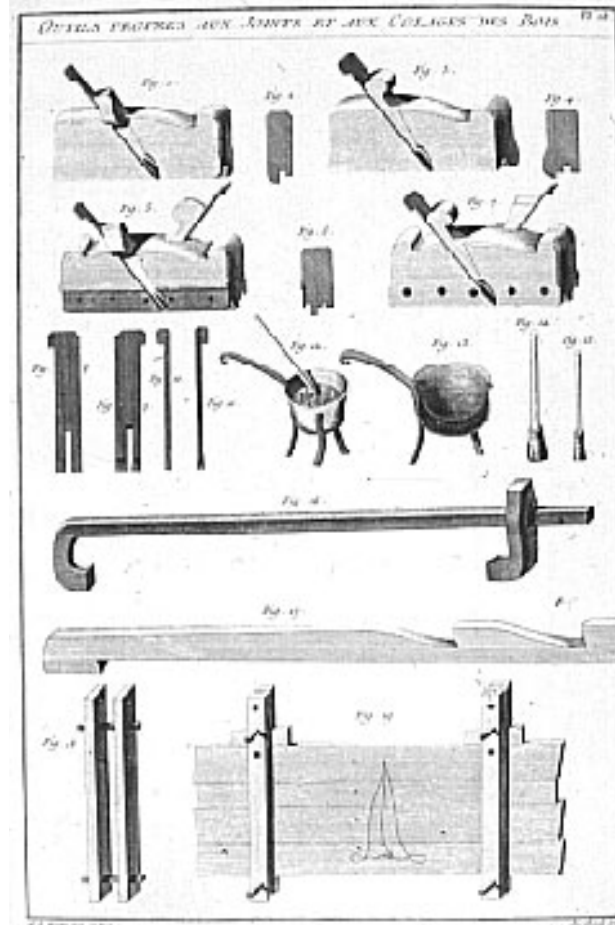

Figure 15

Routing out of the housing across a multi-section panel, as part of the installation of a tapered dovetail batten (from G. Heine's article on historical and technical aspects of tapered dovetail battens [Heine 1984]).

glue alone would seem adequate. Various mechanical fixings, such as battens, loose tongues, tongue and groove, or dovetail keys might also be employed. Battening serves to resist warping as well as to hold several boards together. As G. Heine (1984) has demonstrated, a particularly effective method is tapered dovetail battening, which holds firmly in all directions while permitting a certain amount of shrinkage (Fig. 15). Muller has recorded that both Florentine and Sieneese composite panels are found with internal dowels (Muller 1993). However, properly applied to well-fitted joints and protected from damp, the traditional animal glues have proved their strength and durability over many centuries, even on edges—such as the backs of stringed musical instruments—that are much thinner than those of panels for painting.

Finally, the now-solid board of required dimensions needs a finely smoothed surface to receive the paint. Since geometrical accuracy is no longer as important as in the preparation of the joints, the first approach to this task is with a short plane for smoothing, some 15–20 cm long. If the wood has been carefully selected and does not present any wild or contrary grain, the smoothing plane will achieve a surface ready for finishing with abrasives. If, however, there is difficulty with the grain tearing out in places under the plane, then recourse will be made to scrapers, such as pieces of broken glass or, more recently, thin steel plates the edges of which have been turned to form microscopic hooks.

The ultimate finish has always been achieved by abrasion. The ancient Egyptians used stone rubbers. In Europe various dried fish skins,

or rushes that in their natural growth had picked up silicates, were the norm until the arrival of accurately graded glasspaper. Glasspaper of a sort was available in the eighteenth century, but it must have been coarse or inconsistent, as Sheraton's *Cabinet Dictionary* (1803) states that its use was followed by rubbing with rushes.

---

## Acknowledgments

In an almost undocumented field, that of the woodworking trades before the eighteenth century, it has been necessary to pick up information from a wide variety of sources not originally intended as technical treatises. In this task the author has been greatly helped by the observations recorded by Norman E. Muller, Elliot M. Sayward, and other members of the Tool and Trades History Society and of the Early American Industries Association. The author is also indebted to Elliot M. Sayward for drawing attention to the illustrations that are used in Figure 7.

---

## References

- Heine, G.  
1984 An historically important woodwork joint. *Tools and Trades* (Journal of the Tool and Trades History Society) 2:29–45.
- Muller, N. E.  
1993 Some medieval carpentry tools and techniques. *Chronicle of the Early American Industries Association* 46(4):98–108.
- Roubo, J. A.  
1769 *L'art du menuisier*. Paris: Académie Royale des Sciences.
- Sheraton, T.  
1803 *The Cabinet Dictionary*. London.